

**2009 SCE Participating Load Pilot  
Feasibility Report**

# 1. Table of Contents

1.	Table of Contents .....	2
2.	Executive Summary .....	5
3.	Introduction .....	7
4.	Customer Enrollment.....	10
5.	Systems and Technology Utilized in the PLP .....	12
5.1	Load Control System .....	12
5.2	Load Telemetry System.....	13
5.3	CAISO Connectivity Systems .....	17
5.4	Substation Level Circuit SCADA .....	17
5.5	Indoor Temperature Sensors.....	18
5.6	Future Role of Edison SmartConnect™ in Ancillary Services .....	18
5.6.1	Edison SmartConnect™ data for ancillary services settlement .....	19
5.6.2	Edison SmartConnect™ data for telemetry .....	19
5.6.3	Load Control possibilities .....	20
6.	Event Information .....	21
7.	Assessment of Technical Feasibility.....	24
7.1	Bidding .....	24
7.2	Dispatch.....	26
7.3	Settlement.....	28
7.3.1	PLP Load Drop Quantification.....	28
7.3.2	PLP Load Quantification.....	29
7.4	Technical Challenges for Program Expansion .....	30
7.4.1	Settlement Data Sources .....	30
7.4.2	Telemetry System Range Issues .....	31
7.4.3	System Automation .....	31
8.	Compatibility with Proposed PDR Standards .....	33
8.1	Primary difference between PL and PDR.....	33
8.2	PDR Registration .....	34

8.3	Resource Availability & Outage Reporting .....	34
9.	Other Lessons Learned .....	35
9.1	Rebound effect .....	35
9.2	Temperature as a predictor of underlying load.....	39
10.	Presentation of Algorithms .....	42
10.1	Testing Scope .....	42
10.1.1	Telemetry.....	42
10.1.2	Bidding & Scheduling .....	42
10.1.3	Dispatch.....	42
10.1.4	Metering & Settlement.....	43
10.2	Analysis Methodology .....	43
10.2.1	Overview.....	43
10.2.2	Forecasting what the SCADA load would have been in the absence of load curtailment ...	45
10.2.3	Estimating the Load Impacts of Each Curtailment: .....	46
10.2.4	Total Air Conditioning Load Estimate Based on Proxy Telemetry .....	46
10.2.4.1	Device-level Weights and Alternative Method: .....	46
10.2.4.2	Results: .....	47
10.2.5	Combining Load and Demand Response Data During Dispatch or Restoration Intervals ...	48
10.2.6	Review .....	48
10.3	Observations .....	49
10.4	Comparison with other measurement & verification approaches .....	51
10.4.1	Proposed and Possible PDR measurement & verification approaches .....	51
10.4.1.1	10 day in 10 day proposed baseline methodology for PDR.....	51
10.4.1.2	15 minute interval meter data.....	53
10.4.1.3	Meter Before / Meter After methodology for short duration events.....	56
11.	Ongoing Analysis .....	58
11.1	Customer Feedback.....	58
11.2	Market Assessment and Financial Feasibility .....	58
11.3	Older SDP algorithms .....	59
11.4	Sample Population Variation.....	59

---

11.5	Impact of PLP events on indoor air temperature .....	59
12.	Conclusions.....	60
12.1	Remaining Questions for a 2010 PLP .....	61
12.2	Telemetry for small aggregated loads.....	62
13.	GLOSSARY.....	64

---

## 2. Executive Summary

The objective of SCE's 2009 Participating Load Pilot (PLP) was to explore the technical and economic feasibility of small (less than 5 kW per endpoint) SCE-aggregated Demand Response (DR) in Participating Load (PL) and/or future Proxy Demand Resource (PDR) products for the Measurement and Performance (MAP) markets of the California Independent System Operator (CAISO). The SCE Participating Load Pilot was successful in meeting the deliverables outlined in the Detailed Implementation Plan filed with the California Public Utility Commission (CPUC) on March 11, 2009:

- SCE Launched the PLP by installing proxy telemetry devices in May, dispatching test events starting in June, completing CAISO ancillary services testing in July and bidding, dispatching and settling the PLP resource with CAISO from August through October.
- SCE and its contractor, KEMA, developed algorithms for utilizing 555 proxy telemetry sensors into a forecast of available load for curtailment and provided this proxy telemetry data to CAISO per ancillary services requirements.
- SCE and KEMA developed algorithms to estimate actual load drop after event dispatch based on available SCADA data and interval meter data with additional verification provided by telemetry information.
- Over the course of 20 weeks, SCE conducted 32 Participating Load events. 12 of these events were coordinated with CAISO where SCE bid the PLP resource into the CAISO's day-ahead market for non spinning reserves. The other 20 events were conducted independent of CAISO where SCE did not bid the resource and dispatched the PLP resource without coordination or dispatch instruction from CAISO.

The PLP has demonstrated the technical feasibility of small aggregated air conditioning load to act as a PL resource and has identified that this type of resource would be more

closely aligned with the CAISO proposed Proxy Demand Resource (PDR) market product which requires that only the demand response performance be bid and settled in the wholesale market. Essentially, the PLP resource was able to comply with the CAISO's market process and system requirements for telemetry, bidding, dispatch and settlement. However, the economic feasibility remains a question as the costs for developing and deploying a small aggregated load resource remains unknown. The CPUC recently opened another phase of the Demand Response proceeding to explore "direct participation" per Federal Energy Regulatory Commission (FERC) rule 719 and the results of this proceeding will likely have an impact on the economic feasibility question.

---

### 3. Introduction

In response to the California Independent System Operator's (CAISO) urging that some Participating Load (PL) be ready when Market Redesign and Technology Upgrade (MRTU) Release 1 was deployed, Southern California Edison Company (SCE) proposed to modify its current Demand Response Spinning Reserve Pilot (DRSRP) to evaluate its capability as PL. The objective of SCE's PLP is to explore the technical and economic feasibility of small SCE-aggregated Demand Response (DR) as a potential participant in the MRTU Measurement and Performance (MAP) markets for PL and/or Proxy Demand Resource (PDR) products. SCE and CAISO expected that many lessons would be learned throughout the PLP which may result in recommended changes to CAISO PL requirements or technical specifications to make small aggregated DR load feasible in MRTU MAP.

The scope of the project included developing a "telemetry proxy" to determine available DR, bidding the PLP resource into the CAISO PL ancillary services market, dispatching the PLP resource as scheduled by CAISO upon acceptance of SCE's bid, and settlement of the PLP resource performance based on observed load drop at a specific aggregation point. The greatest challenge to small loads participating in ancillary services is the current CAISO metering requirements including real time 4-second telemetry for monitoring available load and 5-minute metering intervals for settlement. Therefore, the pilot explored the development of a statistical sampling telemetry proxy and utilizing substation circuit level Supervisory Control and Data Acquisition (SCADA) as a metering proxy for settlement in lieu of actual metering at each customer site.

The success criteria for SCE's PLP include:

- Developing processes, procedures and systems both internal to SCE and external interfacing with CAISO to aggregate the PLP resource for bidding into

CAISO wholesale markets as PL, dispatching the resource as a non-spinning reserve ancillary service and settlement of the resource after a PLP event.

- Developing methodologies and algorithms for forecasting and estimating the amount of DR load available by utilizing statistical sampling of the end-use loads as “proxy telemetry” for the entire load and reconciling the estimated load drop with the performance observed at an aggregation point such as the appropriate circuit or feeder SCADA meter.
- Proposing methodologies and algorithms for estimating load drop for small aggregated load DR in the MRTU market for settlement purposes utilizing interval metering at an aggregation point instead of at individual end loads.
- Determining whether the developed methodologies for proxy telemetry and settlement are sufficient for CAISO monitoring and settlement purposes. This will help determine both the economic and technical feasibility of small aggregated load DR functioning as PL or PDR in the MRTU market.

SCE worked with many organizations who were critical to this effort including the CAISO, the California Public Utilities Commission (CPUC), the Dutch energy consultancy KEMA, Lawrence Berkeley National Laboratory (LBNL), BPL Global, equipment installer Good Cents Solutions, Corporate Systems Engineering (CSE) and the National Training Center and Ft. Irwin. KEMA developed the statistical tools used to monitor, forecast and settle the Participating Load. BPL Global provided SCE with telemetry sensors that were used to monitor the participating load and provided data hosting and monitoring services, and Good Cents Solutions installed the telemetry sensors and provided field service at the customer site. Corporate Systems Engineering (CSE) manages the existing Load Control System, updated the test platform for the DRSRP to support the Participating Load Pilot, and manufactures the Summer Discount Plan (SDP) devices. Finally, LBNL provided input on the design of the statistical tools KEMA constructed, guidance on the methodologies employed and extended the



research by supporting additional analysis on the effects of short-term curtailment on indoor temperatures at the test site.

This is a feasibility report based on the first year of SCE's three year Participating Load Pilot. The data and information gathered for this first year have resulted in recommendations on how to proceed in subsequent years. This report will provide an overview of the steps taken during the first year of the pilot, provide details on how the pilot was conducted and detail the results generated so far.

## 4. Customer Enrollment

SCE recruited the National Training Center and Ft. Irwin, thirty four miles north east of Barstow, as the program participant for the Participating Load Pilot. For several reasons, Fort Irwin was the ideal program participant.



**Figure 1 A Google Earth Image of the Ft. Irwin Complex**

- *Marketing & Installation:* Ft. Irwin is a participant in SCE’s Summer Discount Program (SDP), with over 3,200 air conditioning cycling devices installed at the complex. As a result, there was no need to conduct a marketing campaign to recruit residential and commercial customers to the PLP.
- *Ideal climate:* The Ft. Irwin complex is located in the Mojave Desert, where temperatures are consistently high during the summer months. Accordingly, SCE could anticipate significant air conditioning load during the PLP testing period.
- *Ideal location on the grid:* In what amounts to the electrical equivalent of a cul-de-sac, Ft. Irwin lies at the end of a transmission circuit where there are basically no other customers. This relative isolation provided SCE with a significant

advantage during the pilot as the SCADA systems monitoring the two substation circuits provided three-second telemetry reporting on the total base load.

- *Base layout similar to a civilian city:* The structures at Ft. Irwin contained within the red polygon in Figure 1 closely resemble the types of structures one might find in a Southern California suburb such as Irvine or Rancho Cucamonga. This similarity offers SCE the opportunity to extrapolate our findings here at Ft. Irwin to other portions of our service territory.
- *Small size:* The base complex indicated by the red polygon in Figure 1 is only a few kilometers across. For the reasons discussed in the systems section of this report, this compact size made the customer ideal for the telemetry system that SCE selected for the PLP.

SCE provided Fort Irwin an incentive payment of \$100 for each of the 3,255 air conditioner cycling switches participating in the PLP. Using SCE's historical average of 1.4 kW of load per SDP switch, we estimated a total of approximately 4.6 MW of air conditioning load. However, SCE's observations during the PLP tests indicate that this resource may have represented as much as 8.13 MW of load due to a larger population of commercial & industrial complex air conditioners. This analysis is discussed further in the Event Performance section of the report.

SCE's contact with base residents during the PLP was minimal. However, a survey of base leadership as well as base residents is currently being conducted to determine their thoughts and reactions to pilot participation.

---

## 5. Systems and Technology Utilized in the PLP

For the PLP, SCE utilized 4 distinct sub-systems: the load control system; the load telemetry system; the CAISO data processing gateway (DPG); substation level circuit SCADA. In addition, indoor temperature sensors were used to understand impact to customers but were not directly involved in the monitoring, dispatching or settlement of the ancillary services resource.

This section of the final report will address each of these sub-systems in turn. Broadly speaking, the systems utilized in this pilot were acquired to serve a handful of primary business requirements:

- Turning load on and off (the *Load Control System*)
- Measuring the quantity of load available in real time (*Telemetry System*)
- Quantifying, or “Settling”, the amount of load that was curtailed (*Substation level SCADA*)
- Sending telemetry information over the CAISO secure data line called the Energy Communications Network (ECN) into the CAISO *DPG*
- The measurement of indoor ambient air temperature in a sampling of the participating structures was fulfilled by the *Indoor Temperature Sensors*

---

### 5.1 Load Control System

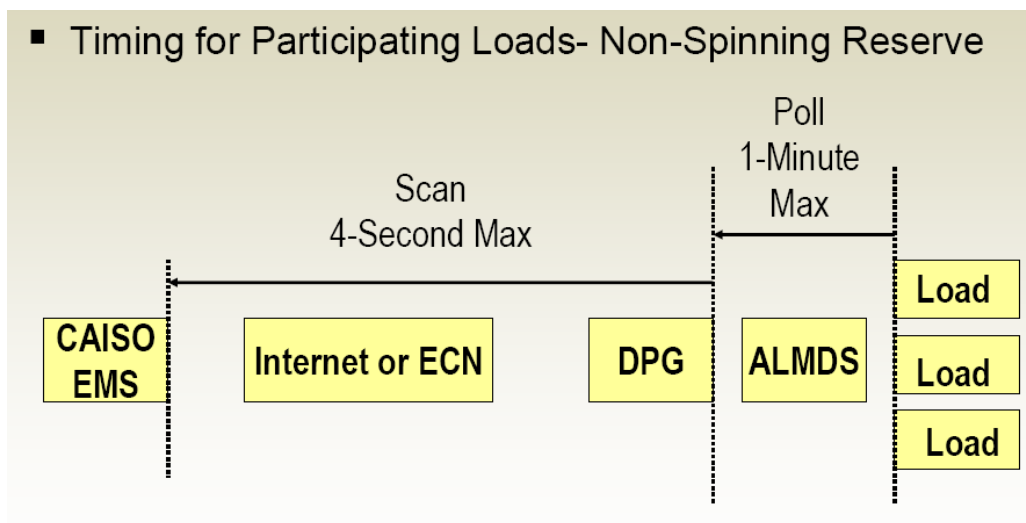
For this pilot, SCE used its existing Alhambra Control System (ACS) network of one-way, VHF-controlled air conditioning cycling switches that was built for the SDP. A testing application previously utilized for the Demand Response Spinning Reserve Pilot<sup>1</sup> (DRSRP) was updated so that the Ft. Irwin switches could be turned off independent of the rest of the full population of over 360,000 SDP participants.

---

<sup>1</sup> Eto, J., J. Nelson-Hoffman, E. Parker, C. Bernier, P. Young, D. Sheehan, J. Kueck, and B. Kirby. 2009. Demand Response Spinning Reserve Demonstration – Phase 2 Findings from the Summer of 2008. (LBNL-2490E). Available at <http://certs.lbl.gov/certs-load-pubs.html>

## 5.2 Load Telemetry System

The underlying technical requirements for both the Telemetry System and the CAISO connectivity system were driven by the CAISO’s specifications for a data processing gateway (DPG) to provide the CAISO with near real-time visibility of the resource availability per the requirements for spinning reserves ancillary services. The DPG technical specification clearly explains the requirements for a load supplying non-spinning reserves, best explained by Figure 2.



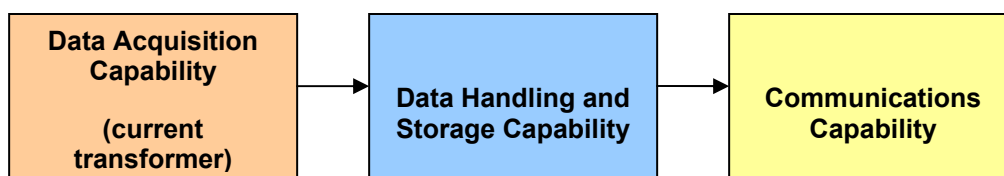
**Figure 2 Timing for Participating Loads - Non Spinning Reserve**

In essence, the CAISO’s standards require the polling of individual loads every minute. The sum of all these aggregated loads is maintained in a subsystem called the Aggregated Load Meter Data System (ALMDS). ALMDS, in turn, reports this sum to the CAISO’s Energy Management System (EMS) every 4 seconds. The DPG system enables the secure transmission of this data between ALMDS and EMS. In practice, the DPG and ALMDS subsystems are usually combined.

SCE’s PLP proxy telemetry system reported an aggregate estimate of the air conditioning load into the ALMDS/DPG. This aggregated estimate was based on an algorithm described in Section 10.2.4 utilizing the telemetry monitoring of 555 air

conditioners out of the total 3,255 air conditioners controlled through the pilot. The load reporting from each individual telemetry device was updated whenever an individual end point load changed by 200 watts or every minute – whichever happened first. CAISO agreed that this approach was appropriate for the pilot, and SCE proceeded to draft a series of technical requirements with which to approach potential telemetry hardware suppliers. SCE’s technical requirements can be summarized as follows:

- Device must report load fluctuations of greater than +/- 3 amps in real time to ALMDS/DPG
- Device must possess some non-volatile memory capability
- Device must possess a unique ID that can be used to mark data transmissions back to the ALMDS/DPG
- Device must be enclosed in a weather-proof, tamper-proof container
- Device must be able to withstand weather conditions present throughout SCE’s service territory
- Device must be UL-listed.



**Figure 3 The Three Components of a Viable Telemetry System**

The proxy telemetry sensor SCE was searching for was essentially a current transformer (CT) that had some type of integral data handling/storage and communications capability, but was not too expensive to install on individual household air conditioners. Unfortunately, the broader telemetry market is geared more towards offering relatively sophisticated data logging devices with significantly more capability than SCE required and which cost thousands of dollars each.

After researching telemetry hardware manufacturers, SCE identified 4 potential hardware suppliers. SCE purchased 12 devices from each manufacturer and performed testing of both the unit accuracy and telecommunications capability utilizing SCE's in-house meter testing group and Information Technology telecommunications group.

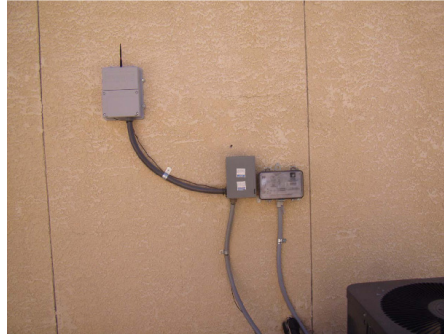
After testing, SCE selected proxy telemetry hardware from BPL Global. BPL Global had also provided the network management and monitoring function for the DRSRP. As described in the application for PLP funding, SCE was leveraging the team and experience from the DRSRP and BPL Global's ability to seamlessly integrate the previous data hosting with the new proxy telemetry devices was a significant factor in the selection.

BPL Global's system, called "Power SG," utilizes a wireless mesh network. Each endpoint load sensor (which can also function as a load controller) communicates back to a data collector via short range radio in the 2.4 GHz spectrum. Each of these nodes has a theoretical open air, line of sight range of about 600 feet. The data collectors are each equipped with a General Packet Radio Service (GPRS) modem that allows them to communicate over standard cellular phone provider networks. One data collector can support up to 5,000 endpoint sensors. The flow of information typically flows from the load sensors back to the Power SG software suite. However, full two way connectivity enables load sensors in the field to be queried independently. The devices also had the capability to interrupt load to their air conditioner, but SCE chose not to utilize this functionality for the PLP .

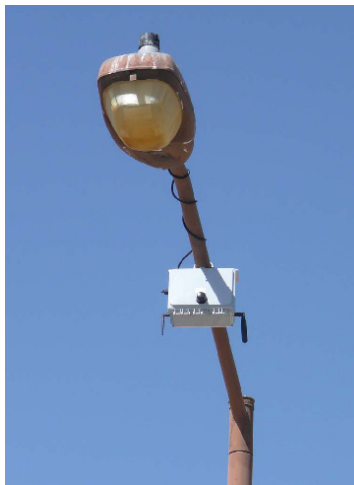
These technical characteristics provided the Power SG with an assortment of advantages:

- Seamless integration between devices in the field and BPL's web-based network management and monitoring software suite.
- High ratio of load sensors to data concentrators reduced cellular data transmission fees.

- Mesh network provided additional network robustness.



**Figure 4 Power SG Load Sensor/Controller Installed on an Air Conditioner (at upper left)**



**Figure 5 Power SG Data Concentrator Attached to a Street Lamp**

The BPL Global PowerSG system provided individual device updates from each of the end points whenever the load changed by 200w or at least once an hour over 99% of the time during the PLP. Whether a similar mesh network system would be the best choice for a larger scale DR program requiring telemetry is an open question and is addressed in Section 7.4.2.





**Figure 6 A Power SG Data Repeater**

---

### **5.3 CAISO Connectivity Systems**

SCE utilized the proxy telemetry data from the 555 monitored air conditioners as input for an estimation algorithm (detailed in Section 10) developed by KEMA to estimate the total air conditioning load for all 3,255 air conditioners as telemetry data for CAISO. BPL Global received the data from the proxy telemetry sensors, processed the data through KEMA's estimation algorithm and transmitted the estimated air conditioning load to CAISO utilizing CAISO's standard DNP 3.0 communications protocol which is commonly used in SCADA applications in the electric and water industries. The SCE PLP resource successfully passed CAISO Ancillary Services Certification testing on July 27, 2009. Completion of this testing certified Edison's telemetry connectivity and allowed SCE to bid the PLP resource into the CAISO wholesale market.

---

### **5.4 Substation Level Circuit SCADA**

Ft. Irwin's previously mentioned isolation on the grid allowed SCE to utilize substation level SCADA as a source of data for determining how much load was actually curtailed from each PLP event. Importantly, this option may not be available in future stages of the PLP, and is addressed in Section 7.4.1.

## **5.5 Indoor Temperature Sensors**

One of the secondary objectives of the PLP is to determine whether or not the short (less than half an hour) duration DR curtailments of air conditioning impact the comfort of the building occupants or whether occupants even notice the events. BPL Global offers an indoor temperature sensor that utilizes the same 2.4 GHz RF communications as the Power SG load controllers. LBNL purchased approximately 100 of these devices and installed them in structures participating in the pilot. SCE and the PLP team were able to monitor the maximum, minimum and average indoor temperatures from the monitored buildings and determine how quickly the building indoor temperatures increased during the 5, 10 and 20 minute duration PLP events. Analysis of the indoor temperature data is continuing in collaboration with LBNL and results will be included in the update described in Section 11.



**Figure 7 BPL's Indoor Temperature Sensor**

---

## **5.6 Future Role of Edison SmartConnect<sup>™</sup> in Ancillary Services**

SCE is in the process of deploying approximately 5 million Edison SmartConnect<sup>™</sup> meters as part of its Advanced Metering Infrastructure (AMI) initiative. The Edison SmartConnect<sup>™</sup> meters will provide 1 hour interval meter data for residential customers

and 15-minute interval meter data for small commercial and industrial customers with less than 200 kW of peak electric demand.

### ***5.6.1 Edison SmartConnect™ data for ancillary services settlement***

CAISO has proposed that 15-minute interval data can be utilized for settlement for the new Proxy Demand Resource (PDR) product by taking the 15-minute data and dividing by 3 to develop the 5-minute interval data required for settlement. This approach is further discussed in Section 10.4.1. It is theoretically possible, but outside of the current Edison SmartConnect™ scope, to configure residential meters for 15-minute interval meter reads as the small commercial and industrial meters are being configured. Thus, because the Edison SmartConnect™ initiative will support only hourly interval data for residential customers, the 5-minute proxy interval data will not be available to support the PL Pilot settlements without technical changes, SCE business case justification and regulatory support for reducing the data interval.

### ***5.6.2 Edison SmartConnect™ data for telemetry***

Edison SmartConnect™ is able to provide near real-time usage information to in-home devices through the Home Area Network (HAN) ZigBee communications and Smart Energy Profile data exchange. However, the AMI infrastructure is not set up to provide this near real-time information back to a central office for purposes of supplying telemetry information in support of ancillary services. While it is theoretically possible that the near real-time usage information could be provided through the HAN to an internet connection, cell phone modem, or another data transmission point in order to approximate telemetry requirements for ancillary services, this functionality will not be available without technical changes, SCE business case justification and regulatory support.

### **5.6.3 Load Control possibilities**

SCE plans to develop an Advanced Load Control System (ALCS) which will enable direct load control signals to be sent through the Edison SmartConnect™ infrastructure to the HAN and customer end-point devices such as programmable communicating thermostats (PCT). The customer program for utilizing the PCT and other HAN devices will initially be Peak Time Rebate (PTR) which incentivizes customers to use less power during peak day afternoons. Additional work will be required to explore and develop retail programs, tariffs and systems which can utilize this new infrastructure to provide ancillary services in the wholesale market where the signals sent to HAN devices would be based on wholesale market dispatches with 10 minute notification and the expectation that the dispatch will be precise. For example, a bid of 5 MW may result in a wholesale dispatch of 4 MW and systems would need to determine which end devices to trigger in order to achieve the proper performance. This functionality will not be available without technical changes, SCE business case justification and regulatory support.

---

## 6. Event Information

Over the course of 20 weeks, SCE conducted 32 Participating Load events. 12 of these events were coordinated with CAISO where SCE bid the PLP resource into the CAISO's day-ahead market for non spinning reserves. CAISO dispatched the resource per a predetermined schedule and SCE submitted settlement data for both the load and demand response elements of the Participating Load. 2 of the 12 events scheduled with CAISO were bid and settled, but not successfully dispatched. The other 20 events were conducted independent of CAISO where SCE did not bid the resource and dispatched the PLP resource without coordination or dispatch instruction from CAISO. These CAISO independent, or "Test", dispatches were run to collect additional data for evaluation of the PLP systems and development of statistical tools for algorithm development. A full list of these events, and the performance of the Participating Load resource during them, can be found in Section 10.3. Table 1 provides an overview of the PLP dispatch dates with CAISO coordinated events marked in blue and test events marked in orange (note that some days had multiple test events).

## 2009 SCE Participating Load Pilot

**Table 1 Calendar of PLP Events**

June 2009							July 2009						
	1	2	3	4	5	6				1	2	3	4
7	8	9	10	11	12	13	5	6	7	8	9	10	11
14	15	16	17	18	19	20	12	13	14	15	16	17	18
21	22	23	24	25	26	27	19	20	21	22	23	24	25
28	29	30					26	27	28	29	30	31	
August 2009							September 2009						
						1			1	2	3	4	5
2	3	4	5	6	7	8	6	7	8	9	10	11	12
9	10	11	12	13	14	15	13	14	15	16	17	18	19
16	17	18	19	20	21	22	20	21	22	23	24	25	26
23	24	25	26	27	28	29	27	28	29	30			
30	31												
October 2009													
				1	2	3							
4	5	6	7	8	9	10							
11	12	13	14	15	16	17							
18	19	20	21	22	23	24							
25	26	27	28	29	30	31							
SCE Independent Event							CAISO Coordinated Event						

PLP events occurred at varying times of the day and during varying days of the work week. SCE and KEMA attempted to engineer dispatches to include a range of test event times, durations and temperatures so that load characteristics could be thoroughly explored. However, SCE did not dispatch the PLP on weekends and it is not within the current scope to incorporate or analyze the different air conditioning load patterns that may arise from weekend usage.

The PLP events were also prescheduled with CAISO so that SCE knew when the dispatch signal would arrive. For a production program, the dispatch signal for ancillary services will not be predictable. However, since the dispatch processes for both CAISO and SCE contained significant manual processes in support of the pilot, it was necessary to schedule the PLP events. In the future, CAISO signals would need to automatically connect to the load control systems to dispatch the proper demand response resource. The resource performance would also need to be monitored to determine whether additional resources should be dispatched, or some of the resource should be restored, in order to conform to the CAISO dispatch instruction. Significant systems and program development is being explored to understand the scope of work required to enable this level of functionality and automation.

---

## **7. Assessment of Technical Feasibility**

Bidding, dispatching and settling any resource in the CAISO's Day Ahead Market requires integrating that resource into multiple pre-existing market processes and systems that have been developed over years of coordination between the CAISO and market participants. These market processes and systems are strictly organized and this section analyzes how well the PL resource integrated with these market participation systems and standards.

The basic theme of this section is that while SCE was able to coordinate the bidding, dispatch and settlement of the Participating Load resource, many processes that are automated in typical market processes were run as manual processes for the PLP. Section 7.4.3 will provide recommendations for how these processes can be automated in a future automated DR system.

---

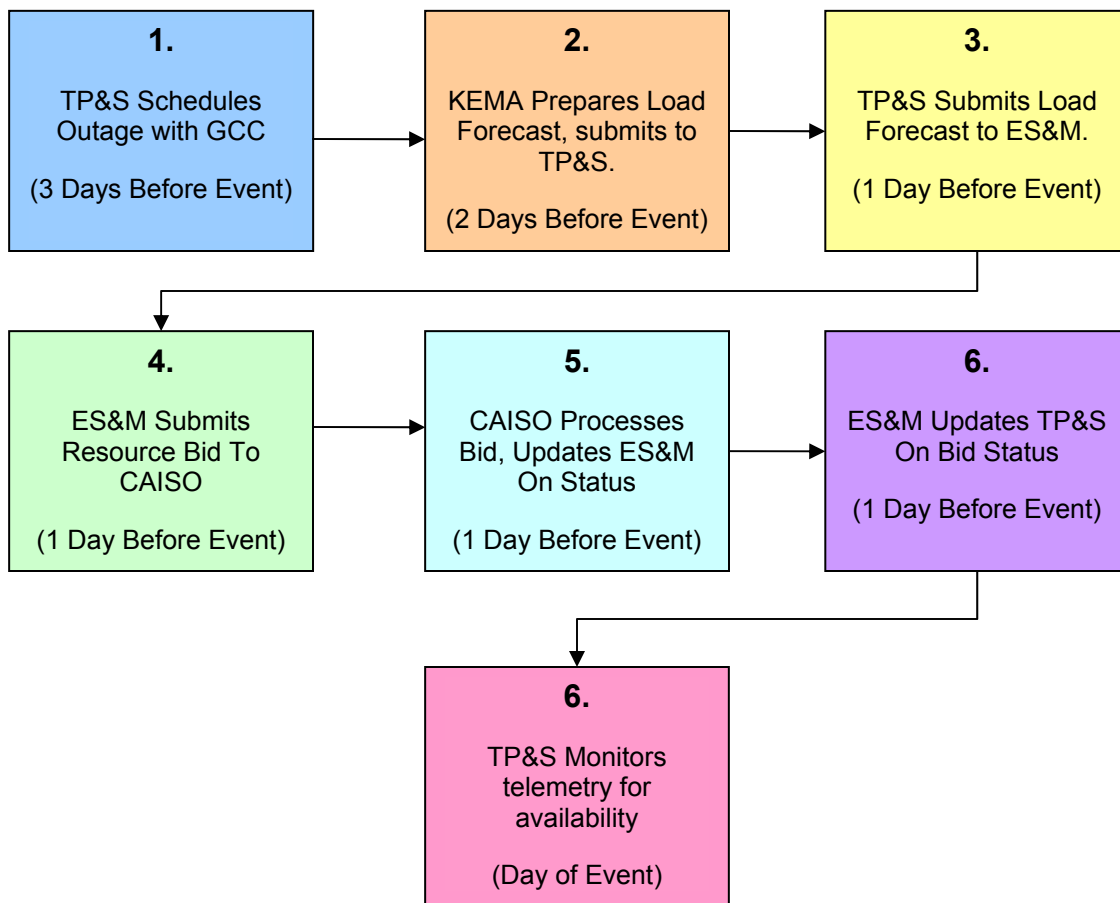
### **7.1 Bidding**

Each of the steps below was performed manually to facilitate the PLP. Each will require a level of automation in order to be performed in support of an actual retail DR program.

1. SCE's Tariff Programs and Services (TP&S) group schedules an event with Edison's Grid Control Center (GCC) operation.
2. KEMA prepares a PLP load forecast based on temperature forecast and estimated load drop figures from prior PL events. KEMA passes this load forecast to TP&S.
3. TP&S submits the load forecast to SCE'S Energy Supply & Management (ES&M) group for use in bid preparation.



4. The Pre-scheduling desk in the ES&M group submits the PLP bid for non-Spinning reserve into the CAISO MRTU Day Ahead Market by 10:00 AM on the day before the event is scheduled.
5. CAISO processes the bid, and informs ES&M whether or not the bid has been awarded. This happens before 1 PM on the day before the event is scheduled. (NOTE: in the PLP, all bids were submitted via the exceptional dispatch process and the bids were never rejected. In a future program, exceptional dispatch would not be used. Therefore, multiple bid award statuses would need to be tracked which would further heighten the need for automation).
6. ES&M calls TP&S to inform them that the bid has been awarded.
7. TP&S monitors real-time telemetry to verify resource availability. In a production program, ES&M may update the bid if significant deviation occurs between real-time telemetry and the original bid value.



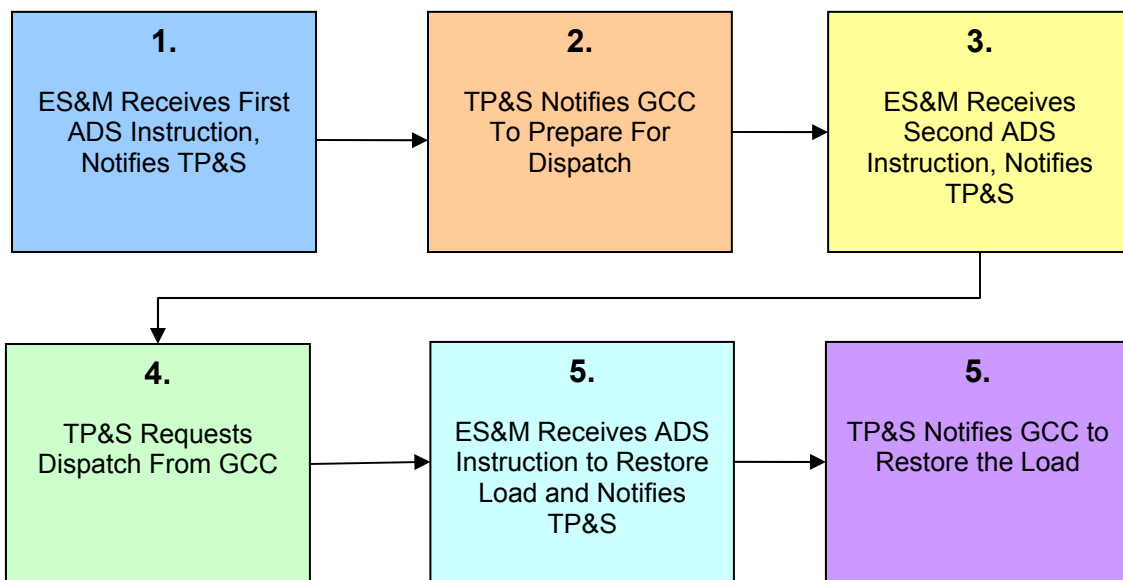
**Figure 8 Bidding Process Flow**

## 7.2 Dispatch

The dispatch process comprised another series of manual processes developed to support the PLP. As with the bidding processes, these dispatch processes and systems will require a significant level of development and automation in order to support any potential future programs. They are reproduced here in order of their occurrence.

1. ES&M receives a preparatory Automated Dispatch System (ADS) instruction from CAISO ADS. These are generator commands that provide five minutes worth of dispatch instructions (e.g., ramp up to X level,

- maintain X output, etc.). ES&M then calls TP&S and notifies them that the ADS signal has been received.
2. TP&S calls GCC and notifies them to prepare for dispatch.
  3. ES&M receives second ADS instruction to immediately curtail load. ES&M notifies TP&S to dispatch the PLP resource.
  4. TP&S notifies GCC to curtail the load.
  5. ES&M receives ADS instruction to restore load. ES&M notifies TP&S to dispatch the PLP resource.
  6. TP&S notifies GCC to restore the load.



**Figure 9 Dispatch Process Flow**

Due to the manual nature of the dispatch process, the PLP did encounter some challenges and delays with the process. For example, telephone communications were sometimes challenging when ES&M attempted to contact TP&S and when TP&S attempted to contact SCE’s Grid Control Center (GCC). This included simultaneous calls coming in to the recipient, delays in one party calling the other due to competing

priorities and other obstacles one would expect when a three step telephone call process is required to dispatch a resource. However, SCE was able to successfully demonstrate that the PLP resource could be dispatched in compliance with the non-spinning reserve requirements.

---

## **7.3 Settlement**

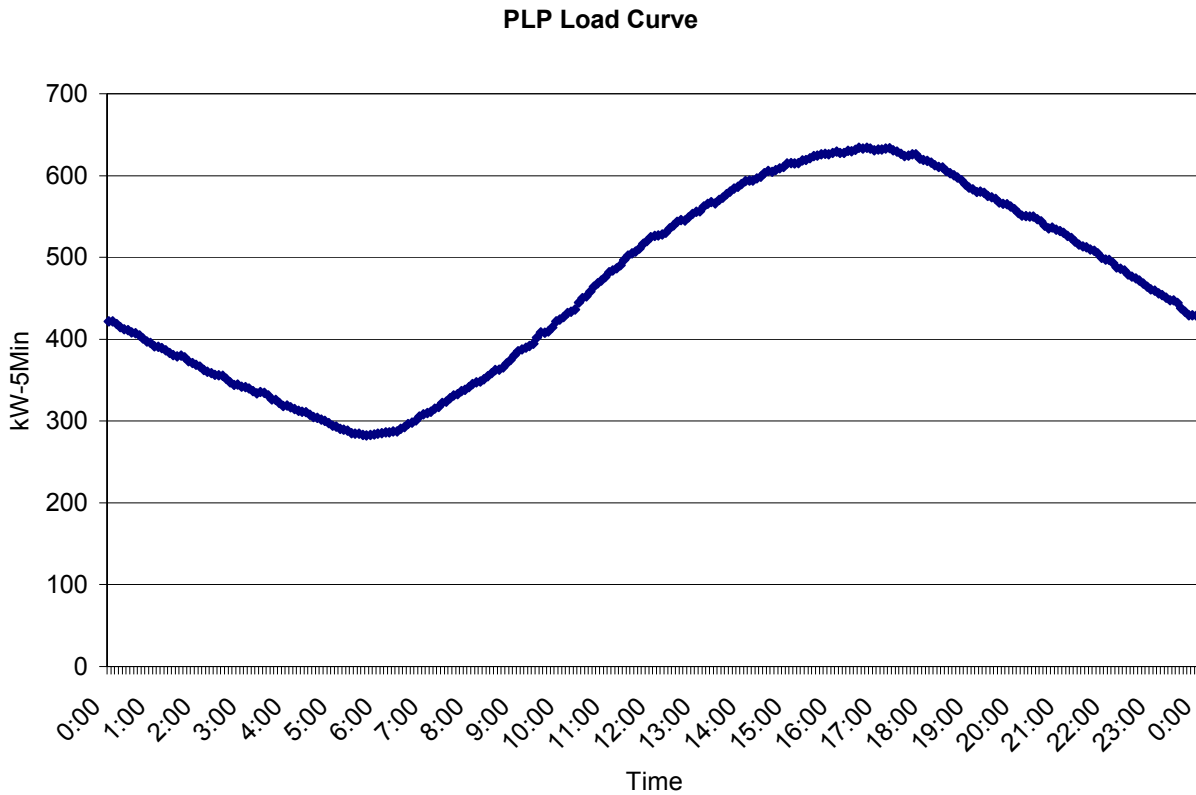
SCE utilized the settlement data calculated by KEMA for submittal to CAISO. Participating Load requires settling both the underlying load and the Demand Response and two different data sources were utilized for quantifying these components for the PLP. The SCE PLP team has explored correlation between observed load drop utilizing the communicating CTs and the observed load drop via SCADA systems at the circuit or feeder level. The load portion of the PL settlement is derived from the total load estimation algorithm based on the proxy telemetry information. The demand response portion of the PL settlement is derived from the observed load drop at the dual circuits feeding the base utilizing SCADA data. The PLP settlement data was submitted to CAISO per the 45 and 90 day requirements for providing metering information for wholesale settlement. SCE also plans to engage the Electric Power Research Institute (EPRI) to perform “shadow settlements” which SCE could use to compare with the CAISO invoices related to the PLP resource.

### ***7.3.1 PLP Load Drop Quantification***

SCE utilized the SCADA data to quantify the load drop for each PLP dispatch. For each PLP dispatch the curtailed load is compared with a baseline load which is produced from an algorithm developed by KEMA. This algorithm utilizes data from non-dispatch event days with a similar load profile to the day with the load drop that is to be estimated. This methodology is detailed in Section 10.2.3.

**7.3.2 PLP Load Quantification**

The PLP load, which represented the load of the air conditioners participating in the pilot, was calculated based upon the proxy telemetry data. Data from the proxy telemetry sensors were entered into the algorithm for estimating the total air conditioning load (see Section 10.2.4). Scheduling different amounts of load based on time of day becomes a dynamic bid not supportable without significant automation. Therefore, CAISO and SCE’s ES&M recommended keeping the PLP load forecast at 5 MW since there would not be any schedule deviations associated with this variance. However, the estimated load was provided to the CAISO through the ALMDS/DPG to fulfill their near real-time load monitoring requirements for non-spinning reserve ancillary services as previously described.



**Figure 10 PLP Air Conditioning Load Curve**

## 7.4 Technical Challenges for Program Expansion

### 7.4.1 Settlement Data Sources

To settle PL resources, CAISO requires 5-minute data intervals. This means that any PL resource must be equipped with a metering device which can collect usage data that is at least as granular as 5 minutes.

The highly granular circuit level SCADA at Ft. Irwin's substation could be aggregated to 5 minute data and then utilized as a proxy meter to measure the base's power consumption. Unfortunately, this "electrical cul de sac" arrangement is rarely found in SCE's service territory. Substations are usually located in arrangements where it is very difficult to assign customers to specific circuits. For the most part, a sudden and substantial drop in power consumption on the substation which fed Ft. Irwin could easily be attributed to one of SCE'S demand response events. However, a sudden, substantial or coincidental load drop on a more typical substation circuit might be the result of any number of activities, such as an industrial customer on that same circuit cycling off an energy-intensive piece of process machinery, or a municipal customer toggling off street lights. This assumes, of course, that load drops will even be noticeable when examining the SCADA data, which is another area of uncertainty.

One proposal for PDR suggests that the CAISO allow the aforementioned 5-minute data intervals to be derived by dividing a 15-minute data interval by 3. Should CAISO accept this suggestion, the advanced meters with 15-minute interval data could be used as sources for settlement data. This could allow commercial and industrial customers to participate in ancillary services. The PLP settlement data derived from SCADA data was compared to the 15 minute interval data to explore the robustness of this approach and the findings are summarized in Section 10.4.1.1.

### **7.4.2 Telemetry System Range Issues**

As mentioned in Section 5, SCE decided to utilize a telemetry system which communicated via a short range wireless mesh network. One of the principal challenges of such a network is that if the distances between communicating sensors, or nodes in the network, increases beyond the range of each node, data repeaters are required to bridge the gap between the two stranded sensors. Additionally, obstructions like tall trees, hilly terrain and tall buildings can act to block signals, forcing the installation of repeaters to “work around” the obstacle.

At Ft. Irwin, neither of these issues proved to be a problem, as base housing participating is clustered closely together. The topography of the base is also basically flat, and devoid of any large trees, heavy vegetation, or tall structures which might obstruct the signal of the Power SG sensor/controllers. In a more typical operating environment, program participants are more likely to be farther apart than 600 feet, and broken terrain, vegetation and tall buildings will be prevalent. These obstacles combined with a sample strategy of monitoring only 1 out of every 10 participating air conditioners could increase the need for signal repeaters thereby increasing the cost of deployment.

### **7.4.3 System Automation**

The PLP required a number of manual workarounds to bid, dispatch and settle the PL resource. Equipping the resource with telemetry, by comparison, remained a largely automated process. Replacing the aforementioned manual workarounds with automation will need to be a critical component of any production level PL program. Any automated PL system would need to fulfill the following requirements<sup>2</sup>:

- Automate notifications to stakeholders when a DR resource bid has been submitted, accepted and dispatched.

---

<sup>2</sup> The requirements list should not be interpreted as a comprehensive listing of system requirements, only a high level overview.

- Process weather and historical load data to automatically prepare and submit Load Forecasts to the ES&M pre-schedule system
- Track the acceptance or rejection of the bids mentioned in Step 1 as they are reviewed by CAISO in the DAM process. Notify TP&S as bids are accepted or rejected.
- Monitor real-time telemetry of load in the hours leading up to each bid dispatch. Automatically notify ES&M when substantial deviations in expected load occur. Modify bids as necessary to reflect changes in real time telemetry data.
- Create an automated system enabling receipt of the CAISO ADS instructions to initiate dispatch, maintain and end the load curtailment in a manner comparable to that used for generators.
- Collect, process and submit Settlement data to Power Procurement settlements group.



## **8. Compatibility with Proposed PDR Standards**

This section highlights SCE's most salient challenges in evaluating the PDR product's ability to include resources comprised of small aggregated loads of the type utilized in this pilot. SCE hopes to further explore these and other aspects of PDR challenges with the 2010 iteration of the PLP which SCE proposes to utilize as a PDR resource (rather than a PL resource) and conduct testing in a more general population circuit if approved by the CPUC.

---

### **8.1 Primary difference between PL and PDR**

One of the core business requirements of Participating Load requires the market participant to forecast and report the quantity of "underlying load" for the Demand Response resource. For large, unitary, loads this is relatively simple. If, for example, the demand response resource is a single large pump at a water handling facility, it is very easy to forecast that underlying load: the pump will either be on or off for the operating interval in question. For small aggregated loads, like those used in this pilot, this requirement becomes much more challenging. Accurately forecasting the underlying load for aggregated air conditioning loads requires accurately predicting the number of air conditioners that will be on in a future interval and determining the tonnage for those air conditioners. If the air conditioners are spread over a wide geographic footprint, with several micro-climates, the task becomes even more difficult.

The PDR product was proposed, in part, to address this difficulty. Market participants that bid their resource as a PDR do not need to schedule underlying load. However, PDR may create some requirements on market participants that could pose challenges for resources comprised of small aggregated loads. Some of these challenges are described in the sections below.

## 8.2 PDR Registration

CAISO requires market participants to “register” their PDR by, among other things, listing the MW value of the PDR. This requirement should be relatively easy to meet for both unitary and aggregated loads. However, the CAISO also states that “once an aggregation is registered, the Demand Response Provider (DRP) cannot change the makeup of that registration without having to resubmit the aggregation for approval.”<sup>3</sup> If a PDR is comprised of 1,000 aggregated air conditioners, and 10 leave the aggregation agreement in a short period of time, does the PDR need to be re-registered? What if 100 leave? SCE’s experience from administering mass-market small load programs like the SDP has been that enrollments are constantly changing as participants relocate or simply decide that they no longer wish to participate. This would introduce the need to constantly re-register the PDR which could become overly burdensome for market participants.

---

## 8.3 Resource Availability & Outage Reporting

CAISO also states that “if an underlying resource in an aggregate PDR has an outage, the entire PDR shall be ineligible to participate in the market.”<sup>4</sup> For loads aggregated from only a handful of resources, this requirement is both easy to ascertain and sensible. This task becomes more difficult for small aggregated loads: if 10 air conditioners in a PDR comprised of 1,000 are malfunctioning or not available, should this PDR be ineligible to participate in the market? What if 100 air conditioners are malfunctioning? It is not clear how this requirement will apply to small aggregated loads.

---

<sup>3</sup> CAISO “*Draft External Business Requirements Specificatio, Demand Response – Proxy Demand Resource (PDR)*”, Version 1.0, October 19, 2009”, Page 14. Available at <http://www.caiso.com/244c/244ced8051fe0.pdf>

<sup>4</sup> CAISO “*Draft External Business Requirements Specificatio, Demand Response – Proxy Demand Resource (PDR)*”, Version 1.0, October 19, 2009”, Page 22. Available at <http://www.caiso.com/244c/244ced8051fe0.pdf>

---

## 9. Other Lessons Learned

---

### 9.1 Rebound effect

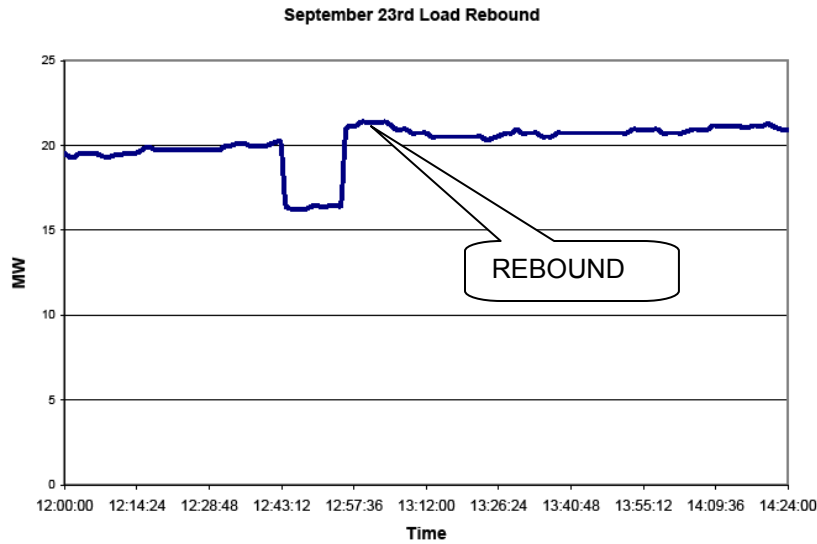
At the end of curtailment events, it is typical for aggregated load to quickly return to a level at or above the level prior to dispatch. On a typical warm day the load generally increases to a level above what would have occurred in the absence of a dispatch event and this is commonly referred to as the “rebound” period.

On warm summer days, most A/C units cycle on and off according to their thermostat setting. Prior to a curtailment event, a unit is either on or off. During a curtailment period a unit that was off prior to dispatch may or may not have cycled on during that event period. Similarly, an A/C unit that was on prior to dispatch may or may not have cycled off.

A post-curtailment event rebound occurs when more units turn on at the end of the event than would have been on had the curtailment event not occurred. While the curtailment events do not make units that would be on anyway run higher, the curtailments have the effect of aligning the phases of many units in the system to some degree. As time goes by, the units fall back out of phase with one another and the rebound fades away. The magnitude and duration of rebound, therefore, depends on the procedures used to “release” A/C units from centralized load control. For 2009, we selected a procedure that dramatized the effect, but intend to explore other procedures in the future using the information gathered this year.

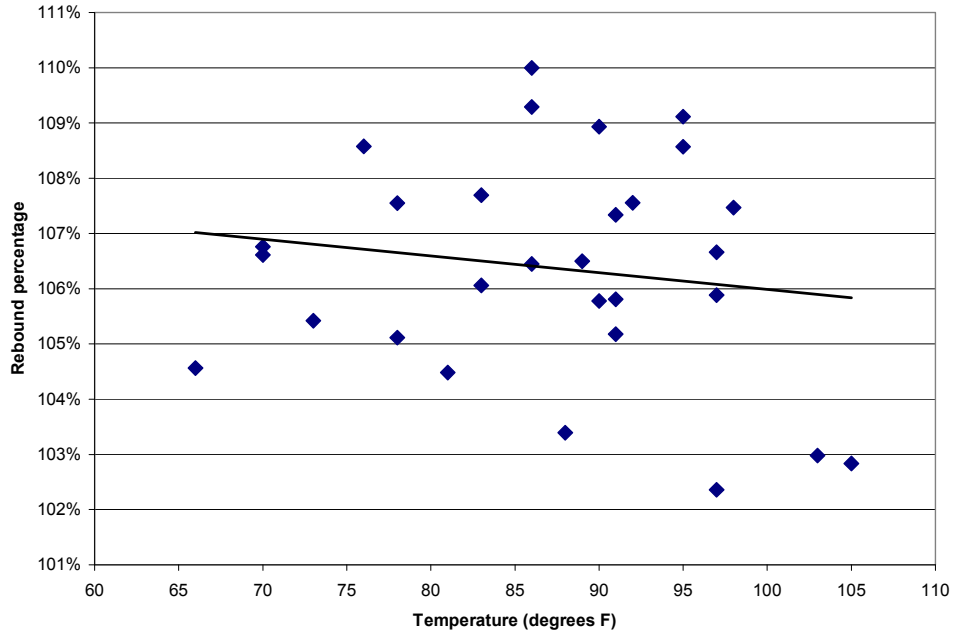
The characteristics of rebounds vary, but in general there is an initial spike with a peak occurring in the first 5 to 10 minutes following the end of the event. The dispatch signals in the 2009 PLP act on the entire population of A/C units, so the spikes are more pronounced than they would have been under a scenario of a staggered release of the units (also known as a randomized restoration which is analogous to a generator

ramping). Following the spike, the load then declines in the next 10 to 20 minutes into a steady trend trajectory that resembles what would have been expected in the absence of a curtailment event. This trend is illustrated by Figure 11 showing the load rebound that was observed on September 23<sup>rd</sup>.

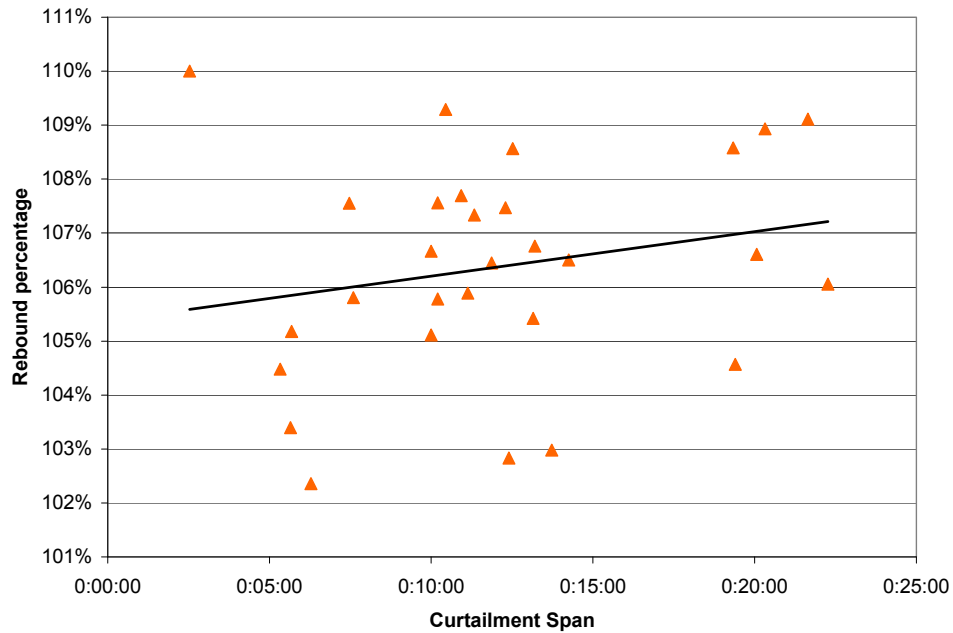


**Figure 11 September 23rd Load Rebound illustrating a rebound**

On average, the rebound resulted in a 6% increase in load compared to what the load-matching technique described in Section 10.2 estimated for what the load would have been in the absence of a demand response event. At minimum, a 2% rebound was observed after the PLP dispatch and a maximum of 10% was observed as shown in Figure 12 and Figure 13 below.



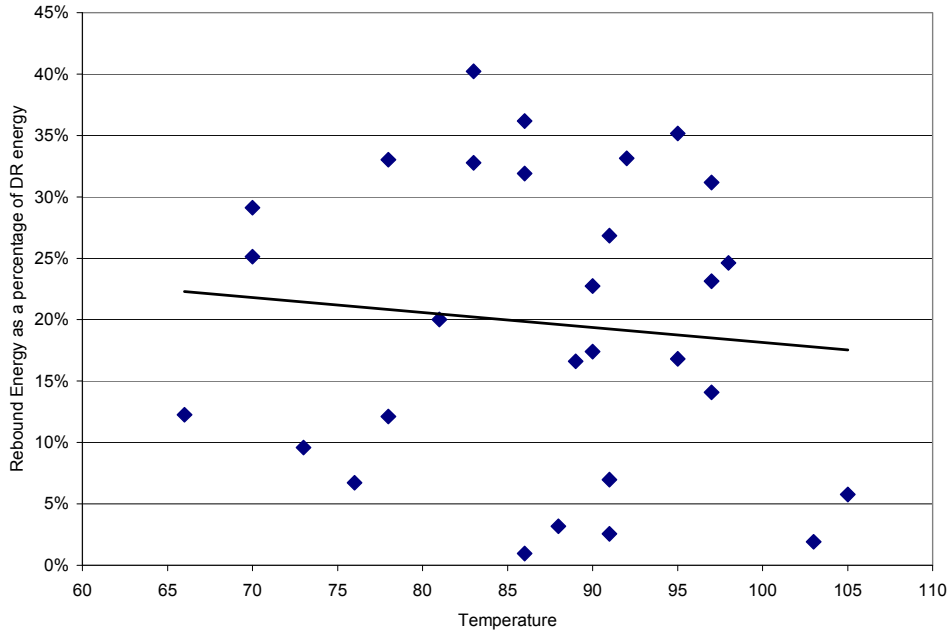
**Figure 12 Rebound as a percentage of predicted average load at given temperatures**



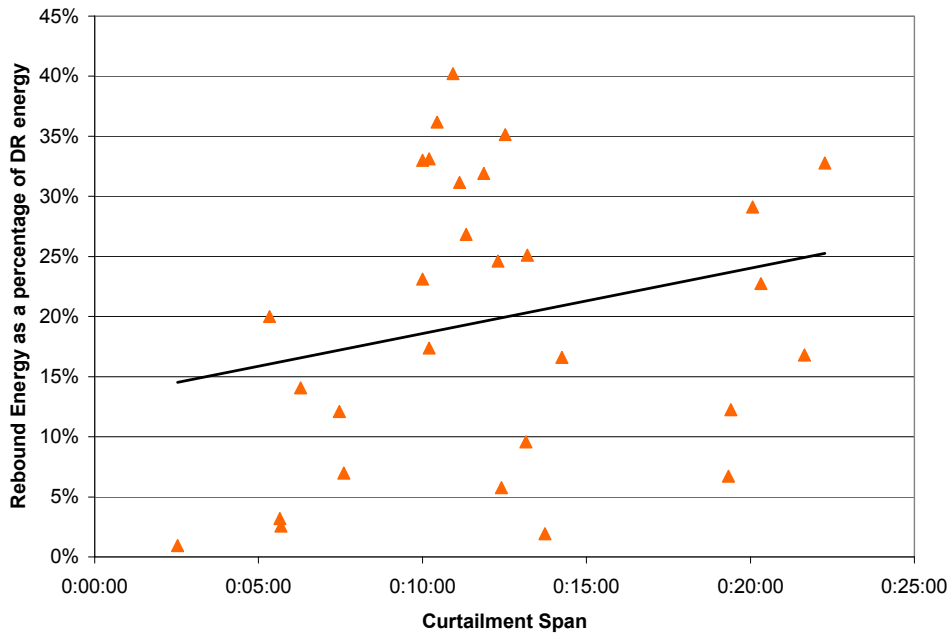
**Figure 13 Rebound as a percentage of average load for different curtailment spans**

In addition, the energy under the rebound portion of the load curve can be significant. On average, the energy of the rebound amounted to 20% of the energy

curtailed during the duration of the PLP demand response event. This amount of rebound energy as a percent of the demand response energy curtailed varied from a minimum of 1% to a maximum of 40% as shown in Figure 14 and Figure 15 below.



**Figure 14 Rebound Energy as a percentage of DR Energy at given temperatures**

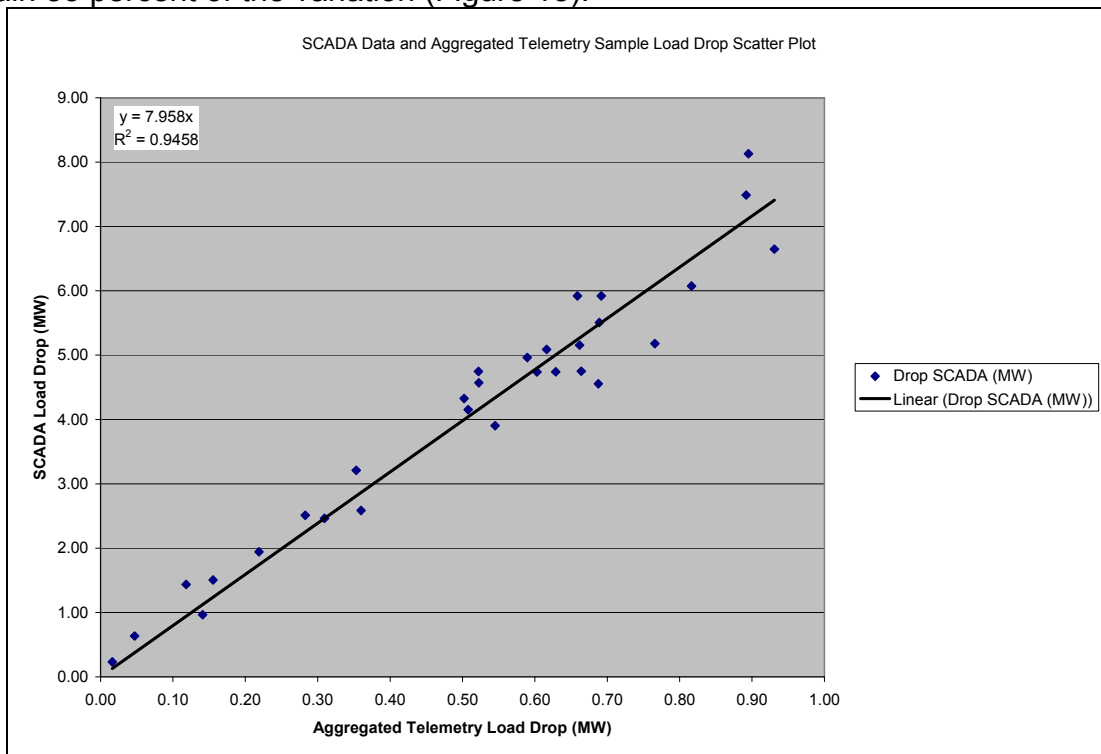


**Figure 15 Rebound Energy as a percentage of DR Energy for different curtailment spans**

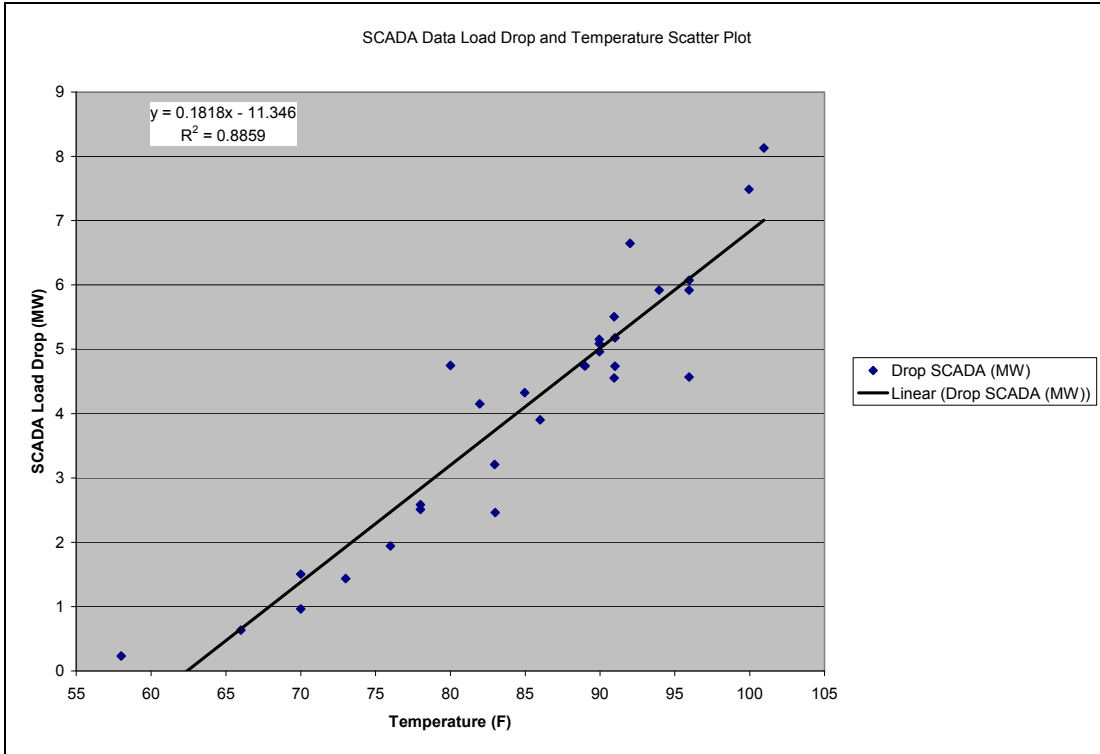
## 9.2 Temperature as a predictor of underlying load

A strong and significant linear relationship exists between outdoor air temperature and A/C load. This allows temperature to function as an alternative estimator of available load reduction, and can also be used to test for bias in the telemetry sample distribution.

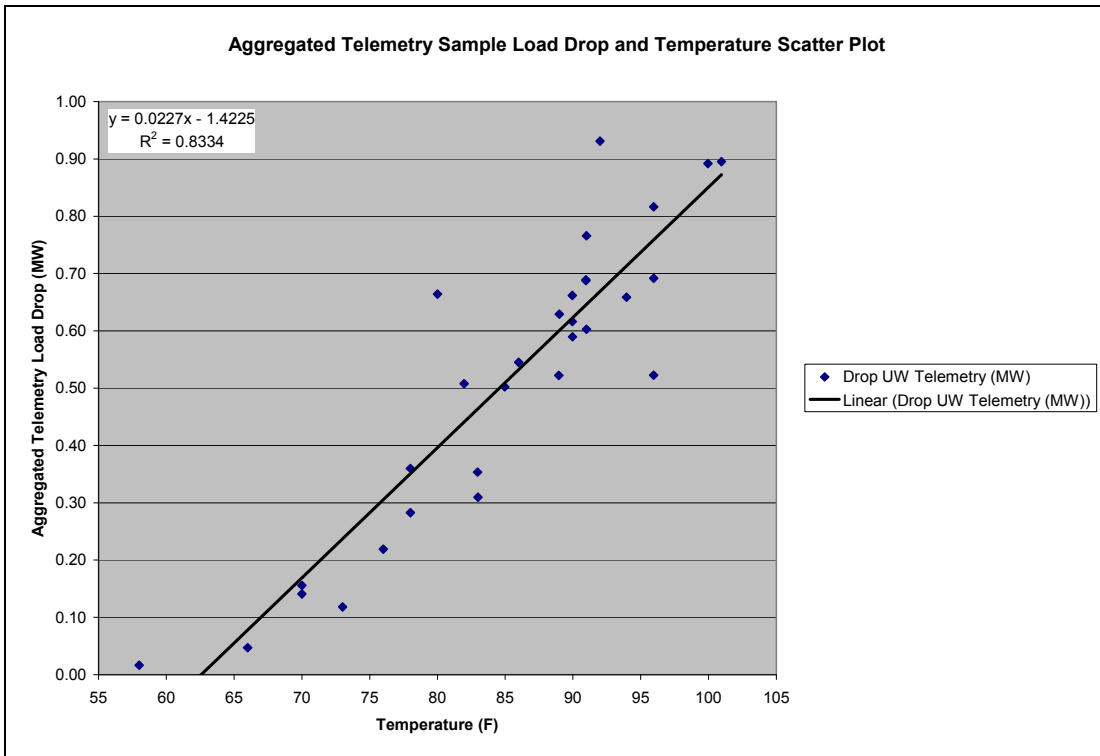
Linear regression analysis methods used in the load impact analysis calculations indicate that sample telemetry data can explain 94 percent of the variation in the SCADA data across curtailment events (Figure 16). For a robustness test, a similar model was calculated using outdoor temperature as the explanatory variable instead of sample telemetry data. The explanatory power of temperature as a variable was not as strong as telemetry data. However, temperature was able to explain 88 percent of the variation in the SCADA data (Figure 17). Temperature was also tested as an explanatory variable for the aggregated telemetry sample load drop where it was able to explain 83 percent of the variation (Figure 18).



**Figure 16 SCADA Data and Aggregated Telemetry Sample Load Drop Scatter Plot**



**Figure 17 SCADA Data Load Drop and Temperature Scatter Plot**



**Figure 18 Aggregated Telemetry Sample Load Drop and Temperature Scatter Plot**



At both the telemetry sample level and the SCADA level, temperature is a very good predictor of load reduction. While not as accurate as telemetry data, it is possible that the performance of a temperature based model may lie within the statistical standards established for CAISO settlement, and could potentially be more cost effective. Theoretically, the telemetry data should be a more accurate estimate of SCADA load reduction than temperature. Keeping this in mind, the performance of a temperature model can potentially be used as a lower bound in testing for a balanced telemetry sample.

---

## 10. Presentation of Algorithms

---

### 10.1 Testing Scope

As described below, SCE's PLP explored enhancements from some of the current CAISO requirements for PL. The intent of the PLP is to explore measurement and verification criteria for small SCE-aggregated DR load and to determine whether the proxies developed for telemetry and metering are acceptable to CAISO.

#### 10.1.1 *Telemetry*

The SCE PLP team developed telemetry proxy algorithms to forecast load reductions based on sample CT data. This report summarizes the methodologies and algorithms developed and utilized for the PLP to satisfy the CAISO requirements for near real-time monitoring of non-spinning reserve ancillary services resources.

#### 10.1.2 *Bidding & Scheduling*

SCE placed bids for non-spinning reserve ancillary service into CAISO's Day-Ahead Market on Wednesdays (for performance on Thursdays) from August 6, 2009 through October 29, 2009 and scheduled the Aggregated Pricing Note (APNode) load for the PLP starting July 27 and ending October 31, 2009.

#### 10.1.3 *Dispatch*

In total, SCE conducted 32 PLP dispatches between June 18, 2009 and October 30, 2009 and 12 of the dispatches were 10 minute events conducted in response to CAISO exceptional dispatches of the PLP resource. The CAISO-independent dispatches performed by SCE varied in duration from 5 to 20 minutes.

### **10.1.4 Metering & Settlement**

To develop proxy data for Settlement, SCE engaged KEMA and LBNL to create the methodologies and algorithms outlined in the next section. The SCE PLP team has explored correlation between observed load drop utilizing the proxy telemetry sensors and the observed load drop via SCADA systems at the circuit or feeder level. The load portion of the PL settlement is derived from the total load estimation algorithm based on the proxy telemetry information. The demand response portion of the PL settlement is derived from the observed load drop at the dual circuits feeding the base utilizing SCADA data.

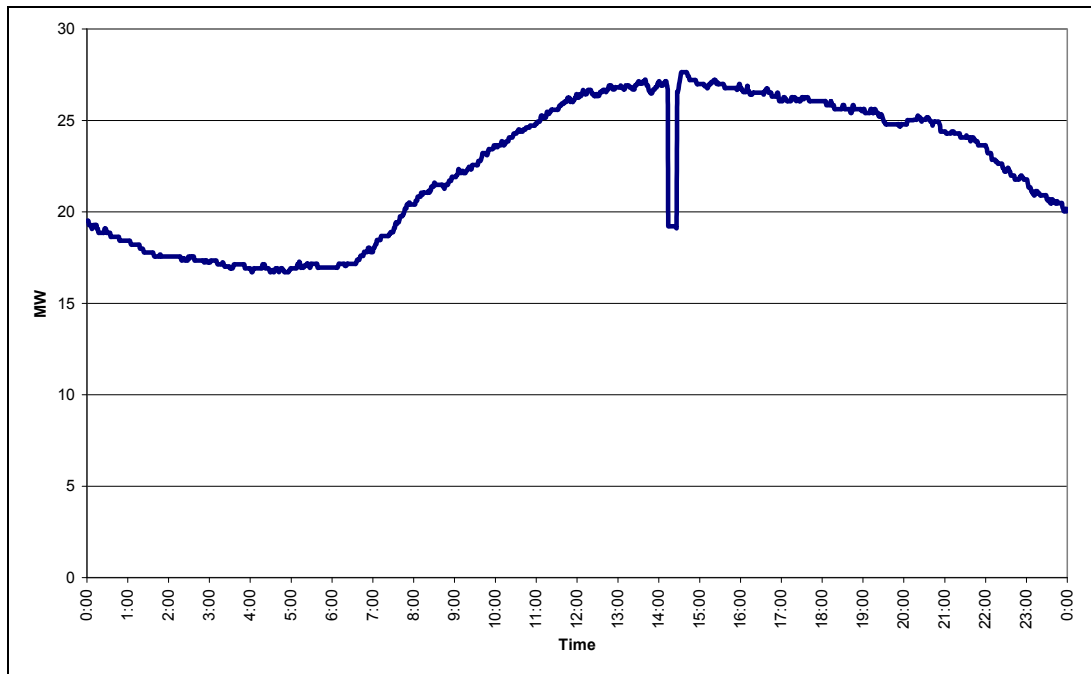
---

## **10.2 Analysis Methodology**

### **10.2.1 Overview**

The Tiefert substation has two sub-feeder circuits, Abrams and Alvord, which supply Ft. Irwin with all of its power. The voltage for the substation and the three current components and reactive power for Abrams and Alvord for timestamps throughout the day for each day are contained in the streams of SCADA output and power is calculated for the system as follows:

$$\text{Tiefert power (MW)} = \text{Abrams power (MW)} + \text{Alvord power (MW)}$$



**Figure 19 Tiefert Substation - Typical Load on PLP testing day**

The actual start and end times of each PLP curtailment are identified by SCADA data around the known dispatch time a current value is significantly less than a timestamp just seconds prior to it. In the case of the PLP and Tiefert substation, these drops tended to be about 25 percent of the load. The curtailment end time is identified in the same manner – finding the easily recognizable timestamp with a significant jump (~25%) in current and assigning the prior timestamp as the curtailment end.

To best assess the amount of demand response achieved for each test, methodology developed for the CERTS Spinning Reserve collaboration with SCE and LBNL and documented in “2008 Demand Response Spinning Reserve Demonstration – Phase 2 Findings from the Summer of 2008 by Eto *et al.*<sup>5</sup>” was leveraged and adapted to fit the data profile for Ft. Irwin.

<sup>5</sup> Eto, J., J. Nelson-Hoffman, E. Parker, C. Bernier, P. Young, D. Sheehan, J. Kueck, and B. Kirby. 2009. Demand Response Spinning Reserve Demonstration – Phase 2 Findings from the Summer of 2008. Available at <http://certs.lbl.gov/certs-load-pubs.html>.

In this study, a load-matching technique was developed to select patterns of loads in periods from days without curtailments that were “closest” to loads on the days with curtailments (and that were recorded at the same time of day as the curtailment). The basic intuition behind this step is that, for any given feeder, the evolution of loads over the course of a day follows a repeatable pattern. By finding matching patterns of loads from similar non-curtailment days for the time immediately prior to the time of a curtailment, we can use the loads recorded at the time of the curtailment from these non-curtailment days to estimate what the load would have been on the curtailment day.

### **10.2.2      *Forecasting what the SCADA load would have been in the absence of load curtailment***

The procedure for forecasting what the SCADA load would have been in the absence of load curtailment is a multi-step process, which can be summarized in the following steps:<sup>6</sup>

1. Measure the load during the interval period immediately preceding the curtailment.
2. Select 12 days from the rest of the feeder data when the load during the same interval immediately preceding the curtailment was closest to that on the curtailment day.
3. Average the loads from the 12 historic days, and take the ratio between the result and the same preceding interval on the curtailment day to obtain an adjustment factor.
4. Take the average load from the 12 historic days for the curtailment interval itself. Use the ratio determined in step 2 to adjust the average for the

---

<sup>6</sup> From section 7.2 of Eto, J., J. Nelson-Hoffman, E. Parker, C. Bernier, P. Young, D. Sheehan, J. Kueck, and B. Kirby. 2009. Demand Response Spinning Reserve Demonstration – Phase 2 Findings from the Summer of 2008. Available at <http://certs.lbl.gov/certs-load-pubs.html>.

curtailment interval. This is the best estimate of what the load would have been had the curtailment not occurred.

5. Interval periods with any overlap of a curtailment were excluded along with the next 30 minutes worth of readings following events so that rebounds did not feed into the algorithm.

### **10.2.3 *Estimating the Load Impacts of Each Curtailment:***

For each of these test events, the estimated load reduction was calculated by subtracting the actual average load from the estimated average load for a period closely matching the time span for the test event. The difference between these is the average amount by which the load was reduced during period.

### **10.2.4 *Total Air Conditioning Load Estimate Based on Proxy Telemetry***

There were 555 A/C units out of a total population of approximately 3,255 that were equipped with telemeter monitoring devices. The data from the 555 unit sample were utilized to estimate the load of the total population as described below.

#### **10.2.4.1 *Device-level Weights and Alternative Method:***

Originally the monitored devices were selected through model based statistical sampling so that the Participating Load could be estimated for the population by weighting up the loads from the installed devices according to their tonnage. The set of sampled units, however, did not match the set of installed units due to compatibility issues with the proxy telemetry devices and some of the air conditioner units at Ft. Irwin.

As an alternative to the original weighting method based on the original sample design, the team developed a technique to use the data from the current set of installed devices to get Participating Load population estimates which are designed to best match load drops during previously observed tests.

The alternative method took the combined unweighted load drop from the installed devices during the test events along with the associated estimated drops from the SCADA data and determined an inflationary factor that related them to one another. Only the load from the devices that had a history of responding to the dispatches were used in the aggregation that was then matched to the SCADA data in determining the inflationary factor. The metered single-phase units still stand for the entire population of Ft Irwin's A/C population, but have weights calibrated to prior tests' SCADA-based ex-post estimates.

As an example, suppose that during a test event the estimated load drop using SCADA data was 5 MW and the unweighted combined drop in load from the telemetry devices was 1 MW. Then an inflationary factor to apply to the 1 MW observed unweighted drop would be 5, so that  $5 \times (1 \text{ MW})$  matched the 5 MW drop in SCADA load.

#### **10.2.4.2 Results:**

Applying the calculated factor to the combined telemetry data for the events, the estimated population drop was within 10 percent of the estimated drop in load from the SCADA data in 24 of the 30 test events and every one where the outside temperature was over 80 degrees. As expected, the relationship deteriorated to some degree as the outside temperatures dropped. This is due to air conditioners representing a small proportion of the overall system load during the fall compared with the summer. Overall, this methodology of using the past event history to produce an inflationary factor to apply to the unweighted combined load of the 500+ units produced results that compare favorably to the drop differences when the population Participating Load estimates were produced using device-level weights.

### **10.2.5      *Combining Load and Demand Response Data During Dispatch or Restoration Intervals***

For settlement purposes, the Participating Load is submitted as positive load values. For the PLP, the Demand Response quantification was based on Circuit SCADA Data (Section 10.2.3) which was subtracted from the estimate of what the SCADA load would have been in the absence of load curtailment (Section 10.2.2). These settlement data are reported in 5-minute aggregated periods with times in the submittal indicating the end of the interval (i.e. 23:05 corresponds with 23:00 to 23:05). The load estimation portion of the PL was estimated utilizing the algorithm for estimating the total load based on the 555 proxy telemetry data points.

### **10.2.6      *Review***

Detailed procedures have been implemented in a manner intended to extract maximum value from the actual recorded performance of loads at Ft. Irwin on an on-going basis. Pattern matching using SCADA loads recorded at the same time of day from non-event days is used to measure the depth of curtailments on event days. Reconciliation between telemetered and estimated curtailments based SCADA loads for past events is used to estimate performance based on telemetered data for future events. Both procedures are updated prior to each new event in order to incorporate all information recorded since the time of the last curtailment.



## 10.3 Observations

High level descriptions of the 2009 PLP events:

**Table 2 Load drop observations**

Date	Test	Curtailement Start	Curtailement End	Curtailement Span	Estimated drop from SCADA (MW)	Estimated drop from weighted Telemetry (MW)	PLP drop as a percent of SCADA drop
6/18/2009	1	11:04:18	11:09:38	0:05:20	3.21	2.89	90%
6/18/2009	2	13:01:07	13:06:46	0:05:39	4.33	4.12	95%
6/18/2009	3	15:03:23	15:10:59	0:07:36	4.75	4.28	90%
6/18/2009	4	17:01:22	17:07:03	0:05:41	4.96	4.83	97%
6/25/2009	5	13:01:22	13:12:42	0:11:20	5.09	5.05	99%
6/25/2009	6	15:01:58	15:13:06	0:11:08	4.55	5.63	124%
7/1/2009	7	12:59:52	13:09:59	0:10:07	5.92	5.40	91%
7/1/2009	8	15:00:24	15:10:24	0:10:00	6.07	6.69	110%
7/9/2009	9	15:04:03	15:25:42	0:21:39	5.51	5.64	103%
7/16/2009	10	15:30:26	15:42:50	0:12:24	8.13	7.33	90%
7/27/2009	11	14:13:12	14:26:56	0:13:44	7.49	7.31	98%
8/6/2009	12	14:00:19	14:11:15	0:10:56	4.15	4.16	100%
8/13/2009	13	13:05:21	13:19:36	0:14:15	5.15	5.42	105%
8/20/2009	14	12:02:04	12:12:16	0:10:12	5.92	5.67	96%
8/27/2009	15	11:02:16	11:12:43	0:10:27	4.57	4.28	94%
9/10/2009	16	16:04:49	16:11:06	0:06:17	6.65	6.83	103%
9/17/2009	17	15:00:37	15:13:08	0:12:31	5.18	5.62	108%
9/22/2009	18	15:00:17	15:20:36	0:20:19	4.74	4.61	97%
9/23/2009	19	12:43:09	12:55:01	0:11:52	3.90	4.00	102%
9/24/2009	20	14:06:05	14:16:17	0:10:12	4.74	4.42	93%
9/28/2009	21	9:00:53	9:08:21	0:07:28	2.59	2.64	102%
9/29/2009	22	15:50:49	16:13:05	0:22:16	4.75	4.87	103%
9/30/2009	23	13:21:21	13:41:25	0:20:04	1.51	1.14	76%
10/1/2009	24	13:01:09	13:14:21	0:13:12	0.96	1.03	107%
10/2/2009	25	10:00:49	10:20:13	0:19:24	0.63	0.35	55%
10/15/2009	26	11:03:28	11:16:37	0:13:09	1.43	0.87	60%
10/16/2009	27	16:35:16	16:37:48	0:02:32	2.46	2.27	92%
10/19/2009	28	12:30:36	12:49:56	0:19:20	1.94	1.61	83%
10/22/2009	29	16:00:35	16:10:35	0:10:00	2.51	2.07	83%
10/30/2009	30	10:45:26	10:54:44	0:09:18	0.23	0.12	52%

**Table 3 Algorithm Performance**

Date	Test	Estimated Drop Difference (PLP-SCADA) in MW	Error Bound for Estimated Average Load Drop Difference at 90% Confidence (MW)	Statistically significant difference at 90% Confidence?	Drop Forecast	Forecast Temp	Actual (SCADA) Temp
6/18/2009	1	-0.26	0.26	YES			81
6/18/2009	2	-0.27	0.31	NO			88
6/18/2009	3	-0.57	0.33	YES			91
6/18/2009	4	0.04	0.25	NO			91
6/25/2009	5	0.00	0.28	NO			91
6/25/2009	6	1.22	0.37	YES			97
7/1/2009	7	-0.56	0.34	YES			98
7/1/2009	8	0.88	0.39	YES			97
7/9/2009	9	0.04	0.39	NO			95
7/16/2009	10	-0.43	0.37	YES			105
7/27/2009	11	-0.26	0.42	NO			103
8/6/2009	12	0.17	0.42	NO	5.13	91.0	83
8/13/2009	13	0.11	0.30	NO	7.50	101.0	89
8/20/2009	14	-0.41	0.31	YES	6.40	98.0	90
8/27/2009	15	-0.35	0.26	YES	6.40	97.0	86
9/10/2009	16	0.18	0.42	NO	6.80	100.0	97
9/17/2009	17	0.44	0.66	NO	5.90	95.0	95
9/22/2009	18	-0.13	0.49	NO			90
9/23/2009	19	0.10	0.38	NO	4.65	88.0	86
9/24/2009	20	-0.32	0.46	NO	5.40	91.0	92
9/28/2009	21	0.05	0.26	NO			78
9/29/2009	22	0.12	0.45	NO			83
9/30/2009	23	-0.36	0.40	NO			70
10/1/2009	24	0.07	0.53	NO			70
10/2/2009	25	-0.29	0.28	YES			66
10/15/2009	26	-0.57	0.34	YES	2.28	75.0	73
10/16/2009	27	-0.19	0.26	NO	4.30	86.0	86
10/19/2009	28	-0.34	0.38	NO			76
10/22/2009	29	-0.44	0.51	NO	3.90	84.0	78
10/30/2009	30	-0.11	0.26	NO	0.00	60.0	58

---

## 10.4 Comparison with other measurement & verification approaches

### 10.4.1 *Proposed and Possible PDR measurement & verification approaches*

#### 10.4.1.1 10 day in 10 day proposed baseline methodology for PDR

The wholesale market product called PDR was still being developed during execution of the 2009 PLP. As a result, the PLP utilized the load-matching technique for developing a baseline described in Section 10.2. Because the CAISO Draft Final Proposal for the Design of Proxy Demand Resource (PDR)<sup>7</sup> outlines an aggregated 10 day-in-10 day (10-in-10) methodology, SCE compared the PLP load-matching technique to the proposed aggregated 10-in-10 methodology for calculating baselines.<sup>8</sup>

In order to make an appropriate comparison between the 10-in-10 and Past Similar Day (PSD) load drop estimation methods, the aggregation periods of SCADA data are the same for both the 10-in-10 and PSD. In each one the data is chosen to be similar in length to the event itself. This is done to minimize errors when the load data is averaged over the aggregation period. The span of days used as an input to the ten-in-ten selection algorithm is June 1st, 2009 to October 30th, 2009 – the day of the final curtailment event.

The estimated load reduction for each PDR event is produced with the actual observed load during the event and a baseline of historical days selected according to the following criteria:

- Exclude previous event days, defined as a day when either a PDR event or outage occurred.
- Exclude different day-types, where day-type is either 1) a weekday or 2) a weekend or NERC holiday.

---

<sup>7</sup> CAISO Draft Final Proposal for the Design of PDR 09/02/2009 <http://www.caiso.com/241d/241da56c5950.pdf>

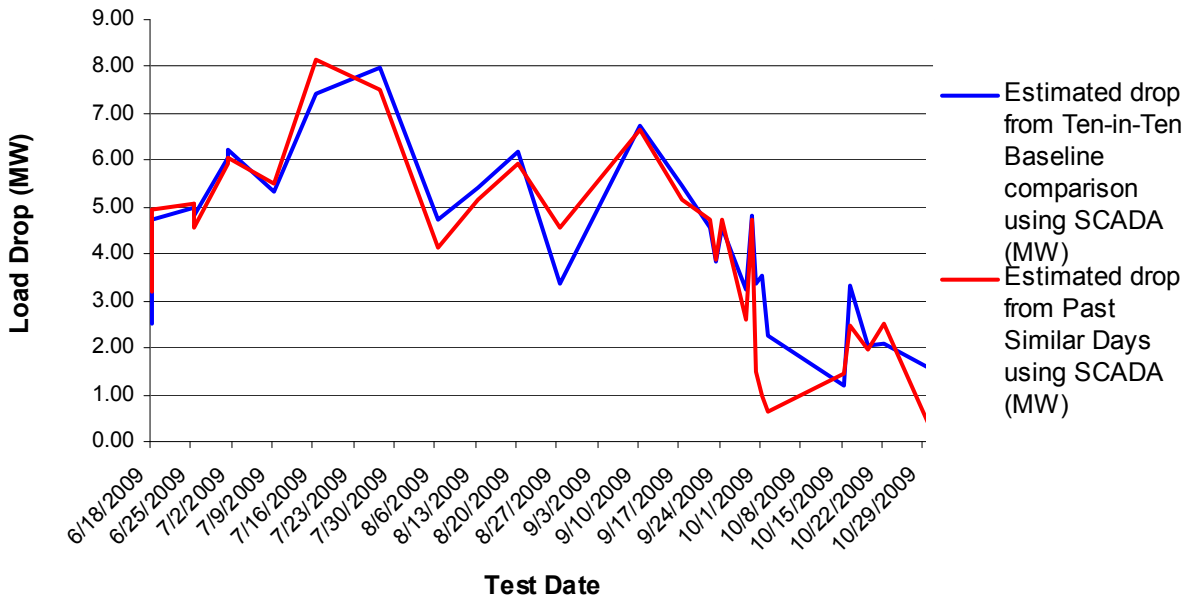
<sup>8</sup> From section 3.8 of the Proxy Demand Resource Draft Implementation Plan. Available at <http://www.caiso.com/2478/24786cd75ad80.pdf>

- Count backwards from event day until target number of days is reached.
- Exclude days earlier than 45 days prior to event.

All of the 30 PDR events occurred on a weekday, between June 18th and October 30th, and for each event 10 baseline days were identified, although some days were excluded per the criteria above.

The two estimation methods produced very comparable estimates of load drop for tests with outside temperature around eighty degrees or more. Starting around September 28<sup>th</sup> (test 21) the comparability of the two sets of estimates began to deteriorate. For tests in cooler weather, the 10-in-10 tended to overestimate the load drop compared to the PSD approach.

**Comparison of 10-in-10 to Past Similar Day load drop estimates**



**Figure 20 10 in 10 Comparison Chart**

### Table 4 10 in 10 Comparison Table

Date	Test	Outside Temperature (degrees Fahrenheit)	Estimated drop from Ten-in-Ten Baseline comparison using SCADA (MW)	Estimated drop from Past Similar Days using SCADA (MW)	Absolute Difference (MW)	Ten-in-Ten as a percentage of Past Similar day (MW)
6/18/2009	1	81	2.51	3.21	0.70	78%
6/18/2009	2	88	3.75	4.33	0.58	87%
6/18/2009	3	91	4.64	4.75	0.11	98%
6/18/2009	4	91	4.73	4.96	0.23	95%
6/25/2009	5	91	5.00	5.09	0.09	98%
6/25/2009	6	97	4.81	4.55	0.26	106%
7/1/2009	7	98	6.06	5.92	0.14	102%
7/1/2009	8	97	6.21	6.07	0.14	102%
7/9/2009	9	95	5.32	5.51	0.19	97%
7/16/2009	10	105	7.43	8.13	0.70	90%
7/27/2009	11	103	7.96	7.49	0.47	106%
8/6/2009	12	83	4.75	4.15	0.60	114%
8/13/2009	13	89	5.41	5.15	0.25	105%
8/20/2009	14	90	6.20	5.92	0.28	105%
8/27/2009	15	86	3.37	4.57	1.20	74%
9/10/2009	16	97	6.75	6.65	0.10	102%
9/17/2009	17	95	5.45	5.18	0.27	105%
9/22/2009	18	90	4.57	4.74	0.17	96%
9/23/2009	19	86	3.84	3.90	0.06	99%
9/24/2009	20	92	4.57	4.74	0.16	97%
9/28/2009	21	78	3.23	2.59	0.65	125%
9/29/2009	22	83	4.83	4.75	0.08	102%
9/30/2009	23	70	3.39	1.51	1.88	225%
10/1/2009	24	70	3.54	0.96	2.58	368%
10/2/2009	25	66	2.26	0.63	1.63	357%
10/15/2009	26	73	1.19	1.43	0.24	83%
10/16/2009	27	86	3.32	2.46	0.86	135%
10/19/2009	28	76	2.05	1.94	0.11	105%
10/22/2009	29	78	2.07	2.51	0.44	83%
10/30/2009	30	58	1.56	0.23	1.33	677%

#### 10.4.1.2 15 minute interval meter data

A possible alternative to using SCADA-estimated load drops for settlement was to estimate the demand response to test events with TOU-8 15 minute interval meter data. This was investigated by first dividing the fifteen minute intervals evenly into five minute intervals, the interval length used in the settlement worksheets. The energy readings were then converted to average load for the five minute interval. The average

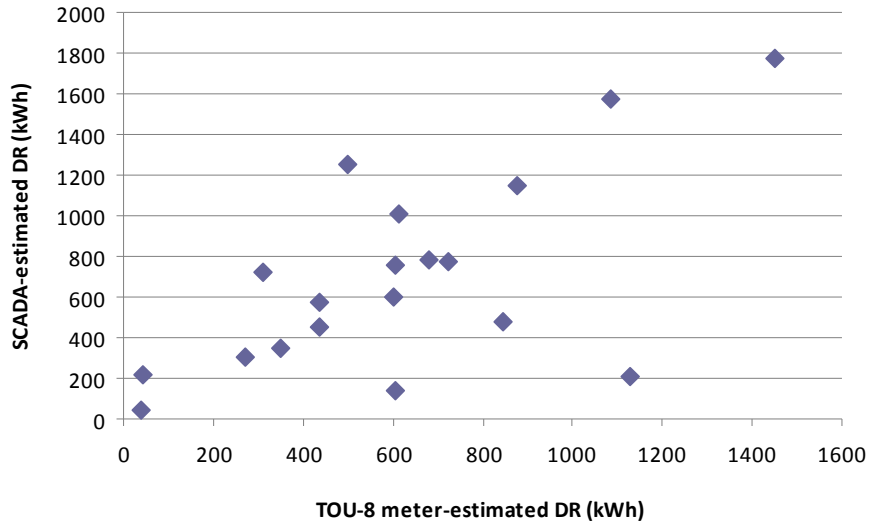
load data was then input to the 10-in-10 load drop algorithm, described in Section 10.4.1.1, which produced estimates of the load drops in each of the test events after 8/5/2009, the date that the meter was replaced.

Following the average load drop estimation, the resulting estimates were converted back into energy. The average load drops and the curtailment proportions for the five-minute aggregated periods were then converted to demand response (DR) by multiplying the curtailment proportion by the energy drops for five minute periods that happened to overlap with the span of a test event.

In the settlement worksheets, DR could not exceed the kWh from the PL, calculated using the weighted total of the telemetered average load for matching five-minute aggregated intervals and then converted to kWh. To make a fair comparison, the TOU-8 meter data-measured DR was capped at the same level as the SCADA-measured DR.

The estimated DR using the TOU-8 meter data tended to be less than with the more reliable SCADA data both overall and on the hotter test days and about the same in the cooler days. They tended to be the same on those days because the estimated savings energy eclipsed the estimated energy consumption from the air conditioner population. This was due to a relatively low proportion of the total household energy consumption going to space cooling, making cooling load and energy very difficult to estimate using feeder-level data.

**Settlement DR Comparison Using SCADA vs. Meter Data for Tests 12-30**



**Figure 21 Settlement Methods Comparison Graph**

**Table 5 Settlement Methods Comparison Table**

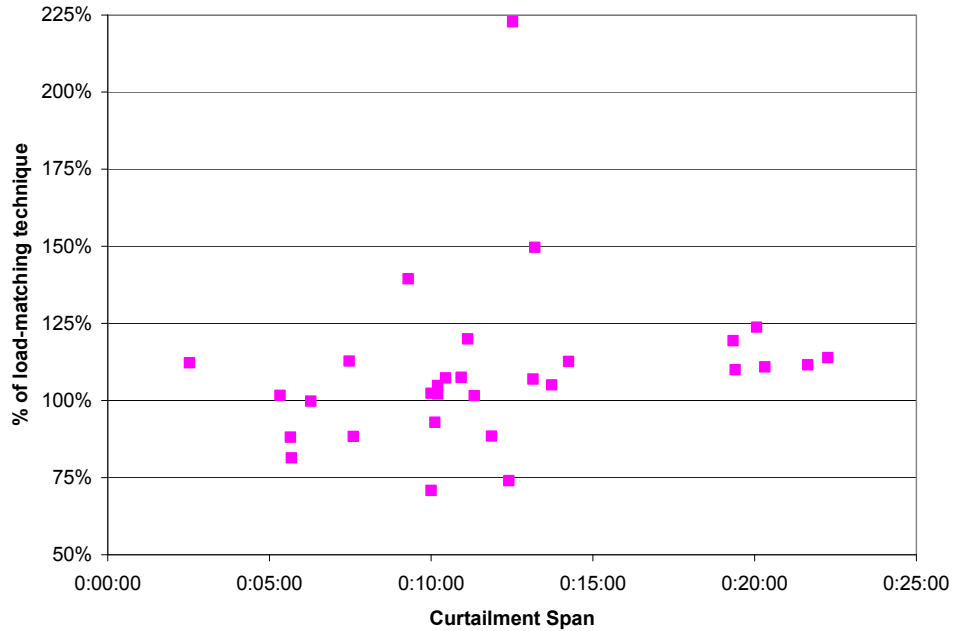
Test	Temperature	Demand Response (kWh)	
		TOU-8	SCADA
12	83	607	760
13	89	501	1249
14	90	612	1012
15	86	681	784
16	97	436	577
17	95	876	1148
18	90	1085	1576
19	86	723	776
20	92	309	720
21	78	273	306
22	83	1452	1775
23	70	845	475
24	70	1126	213
25	66	604	140
26	73	352	352
27	86	43	217
28	76	602	602
29	78	438	448
30	58	40	40
Total kWh		11,605	13,169

**10.4.1.3 Meter Before / Meter After methodology for short duration events**

Another approach called “meter before / meter after” has been discussed in lieu of a baseline calculation approach for short duration demand response events like those that may be associated with ancillary services. The “meter before / meter after” baseline methodology identifies the last reading before the start of each event and the first reading after the end of each event in the SCADA data. The load estimate for the curtailed period is the line segment connecting these two points. To achieve a single number for load reduction during each event, the average of the observed load and the average of the estimated load during the event are calculated. The average of the estimated load is the average of the two segment endpoints. The calculated load reduction is the difference between the estimated load and the observed load for each curtailment event.

In general for the short duration events utilized for the PLP, the meter before / meter after methodology yielded similar results to the load-matching technique described in Section 10.2. On average, the meter before / meter after methodology resulted in estimating 9% more load drop than the load-matching technique. There was one outlying event where the meter before / meter after methodology resulted in estimating the load drop as 11.5 MW compared with the load-matching technique estimate of 5.1 MW. Otherwise, the meter before / meter after methodology yielded results +23% or – 27% relative to the load-matching technique estimate.





**Figure 22 Meter Before / Meter After load drop estimate as a percentage of the load matching technique utilized for the PLP**

As noted in Section 9.1, there is a rebound effect associated with the utilization of aggregated air conditioning load for demand response. The selection of the “meter after” point can have a significant effect on the calculation if the point resides within the rebound period by increasing the load estimate.

---

## **11. Ongoing Analysis**

The SCE team made every effort to completely analyze the data generated during the 2009 PLP for inclusion in this report. However, due to the volume of information generated as well as the common occurrence of each answer generating additional questions, some questions remain unanswered as the analysis continues. This section outlines some items still under development and SCE proposes to provide an update to this report at the end of the 1<sup>st</sup> quarter of 2010 which will include finalization of these items as well as formalizing responses to any questions that arise by stakeholders and observers after their review of this report.

---

### **11.1 Customer Feedback**

SCE is conducting a survey of both Ft Irwin leadership as well as the base residents who were selected to receive the indoor air temperature sensors. The responses to the survey may provide insight into how residents utilize their air conditioning as well as whether the short duration PLP events were noticed during the summer. The survey responses are still being collected prior to analysis, so the reporting of the results will not be available until Q1 2010.

---

### **11.2 Market Assessment and Financial Feasibility**

SCE and the other IOUs continue participation in the DR cost effectiveness proceeding at the CPUC. SCE would like to review the results of the PLP with the team most involved with the cost effectiveness work to ensure consistency of methodology, factors and approach. A complete review was not completed in time to include a financial feasibility section within this report. However, SCE will review financial feasibility with the cost effectiveness team while also monitoring both the CAISO PDR proceeding and

CAISO Direct Participating proceeding to understand how market and retail rules will affect the cost effectiveness of any potential future programs.

---

### **11.3 Older SDP algorithms**

SCE has utilized algorithms to analyze the enrolled MW in SDP and also review the performance of past events. SCE will review the algorithms utilized for SDP and compare them to the results generated by the PLP.

---

### **11.4 Sample Population Variation**

SCE utilized 555 telemetry sensors to estimate the near real time load for a population of 3255 air conditioners. This is a 17% sample population. SCE and KEMA will perform an analysis of the 2009 data to determine how the precision of the estimated total load is affected or degraded as the size of the statistical sample is reduced. This analysis may provide insight into what may be a good size for sampling if a proxy telemetry sample is acceptable for future ancillary services. For example, the load estimate may become significantly less accurate with a sample population lower than 9%. In that case, SCE may recommend that 1 out of 10 aggregated units be equipped with telemetry sensors to provide proxy telemetry data.

---

### **11.5 Impact of PLP events on indoor air temperature**

As mentioned in Section 5.5, analysis of the indoor temperature data is continuing in collaboration with LBNL. Preliminary analysis shows significantly less than a degree of temperature rise in the 110 buildings monitored with temperature sensors during all 30 PLP events.

## **12. Conclusions**

The objective of SCE's 2009 PLP was to explore the technical and economic feasibility of small SCE-aggregated Demand Response (DR) as a potential participant in the MRTU Measurement and Performance (MAP) markets for PL and Proxy Demand Resource (PDR) products. The SCE Participating Load Pilot was a success by meeting the deliverables outlined in the Detailed Implementation Plan filed with the CPUC on March 11, 2009:

- SCE Launched the PLP by installing proxy telemetry devices in May, dispatching test events starting in June, completing CAISO ancillary services testing in July and bidding, dispatching and settling the PLP resource with CAISO from August through October.
- SCE and KEMA developed algorithms for converting a statistical sampling of the monitored current at customer sites into a forecast of available load for curtailment and provided this proxy telemetry data to CAISO per ancillary services requirements
- SCE and KEMA developed algorithms to estimate actual load drop after event dispatch based on available SCADA data and interval meter data with additional verification provided by telemetry information.

The SCE team is still in the process of analyzing the vast amount of data collected during PLP execution. While SCE has demonstrated that small aggregated DR load is technically feasible for participation in MRTU MAP market for PL and PDR products, the economic feasibility question will take more time to develop and will likely leverage the results of a 2010 PLP which SCE hopes to propose.

SCE will also develop recommendations for CAISO based on PLP results. These recommendations will be primarily based on reducing the cost of implementation as well

as maintaining a network of small aggregated load PL or PDR resources while maintaining a predictable and reliable level of resource performance.

---

### 12.1 Remaining Questions for a 2010 PLP

While the 2009 PLP successfully addressed a number of outstanding issues concerning the technical and economic viability of a small aggregated loads participating in the wholesale markets, some questions remain. These include:

- Can small aggregated loads reliably participate as a PDR in the wholesale markets for energy and ancillary services?
- How effective is a mesh networking technology for telemetry in a more typical operating environment?
- Non-spinning reserves resources are typically bid many hours during the year, and called upon to perform with little warning. However, in this pilot SCE had ample warning to prepare for dispatch, as the dispatch time was known a week in advance. As a result, manual processes were able to support pilot operations. However, a significant level of automation would be required to receive and dispatch wholesale market ADS commands that are not scheduled in advance.
- How distinguishable will the A/C load and dispatch be on a more general population substation SCADA system that may have more “noise” from different loads and what is the lowest level of sample telemetry that can be provided before the resource can no longer be reliably counted on for non-spinning reserves?
- How reliable is an air-conditioning-based resource when developed in a region where summer temperatures are not uniformly hot and dry?
- What sort of marketing and customer education issues must SCE resolve to develop and enroll customers in a CAISO wholesale market compatible program?

- How will randomization impact performance and potentially reduce the rebound effect when utilizing a randomization dispatch and restore which is similar to a generation ramp rate?
- What will be the effect of a 50 percent cycling strategy or Programmable Communicating Thermostats (PCTs) be on resource performance and the rebound effect?

---

## **12.2 Telemetry for small aggregated loads**

The CAISO requirement that all loads functioning as an Ancillary Service be equipped with telemetry capable of 1-minute aggregation to an ALMDS/DPG, with 4 second reporting from there seems to be driven by two primary factors: (1) having real-time telemetry available allows market participants to view their load's availability in real-time, allowing for adjustment of bids under circumstances where actual load value deviates from the quantity of load that was forecast and bid; and (2) the telemetry requirement gives the CAISO real-time load visibility of the load resource for use in grid management operations.

The SCE PLP demonstrated that under the ideal circumstances of the Ft. Irwin complex, a 15 percent proxy telemetry solution could be installed to provide a telemetry proxy estimation without monitoring each individual end point load. The question remains whether the cost of telemetry is outweighed by the benefit that telemetry provides. The value of telemetry for ancillary services must be considered in the context of other forms of "load intelligence." Here Section 9.2 is apropos; as it illustrates the potential of accurate weather data to forecast the availability of small, aggregated air conditioning load. Importantly, said weather data is not quite as accurate in predicting load as telemetry, but given the fact that accurate weather data is already readily available, while a telemetry proxy would need to be deployed at potentially a significant expense, its value should not be discounted. SCE recommends an examination of the

Ancillary Services Telemetry requirement to determine whether a proxy telemetry approach or even a temperature based estimation for air conditioning load would provide load estimates that are “good enough” for wholesale market operations.

## 13. GLOSSARY

<b>Term or Acronym</b>	<b>Definition</b>
A/C	Air Conditioner
ADS	Automated Dispatch System
AMI	Advanced Metering Infrastructure
CAISO	California Independent System Operator
CERTS	Consortium for Electric Reliability Technology Solutions
CLAP	Custom Load Aggregation Point
CT	Current Transformer
DDR	Dispatchable Demand Resource
DLC	Direct Load Control
DR	Demand Response
DRSRP	Demand Response Spinning Reserves Pilot
FERC	Federal Energy Regulatory Commission
MAP	Markets & Performance (formerly MRTU Release 1A)
MRTU	Market Redesign & Technology Update
PDR	Proxy Demand Resource
PL	Participating Load
PLP	Participating Load Pilot
SCADA	Supervisory Control And Data Acquisition
SCE	Southern California Edison
SDP	Summer Discount Plan
WG2	Working Group 2